

EiceDRIVER™ 2EDR8259H, 2EDRx259X, 2EDRx258X

Dual-channel isolated gate driver ICs in 300 mil DSO package

EiceDRIVER™ 2EDR8259H, 2EDRx259X, 2EDRx258X is a family of dual-channel isolated gate driver ICs, designed to drive Si and SiC MOSFETs and GaN HEMTs power switches. All products are available in a DSO package with 8 mm input-to-output creepage and provide reinforced isolation by means of on-chip coreless transformer (CT) technology. 2EDRx259X and 2EDRx258X variants in a 14-pin DSO package offer increased channel-to-channel creepage. They are suited for use in applications with higher bus voltage or higher pollution degree and, in general, can ease PCB routing. All versions offer optional shoot-through protection (STP) and dead-time control (DTC) functionality. This allows the operation as dual-channel low-side, dual-channel high-side or half-bridge gate driver with a configurable dead-time. With excellent common-mode transient immunity (CMTI), low part-to-part skew and fast signal propagation, the products are best suited for use in fast-switching power conversion systems.

Features

- 2-channel isolated gate driver for Si and SiC MOSFETs and GaN HEMTs power switches
- Fast input-to-output propagation (38 ns) with excellent stability (+9/-5 ns)
- Strong output stage: 5 A/9 A source/ sink
- Fast output clamping for $V_{DDA/B} < UVLO$
- Fast UVLO recovery time ($< 2 \mu s$)
- Four $V_{DDA/B}$ UVLO options: 4 V, 8 V, 12 V, 15 V
- $CMTI > 150 V/ns$
- Available in 16/14-pin 300 mil DSO package

Isolation and safety certificates

- UL1577 with $V_{ISO} = 5700 V_{RMS}$ (certification n. E311313)
- VDE0884-11 with $V_{IOTM} = 8000 V_{pk}$, $V_{IORM} = 1767 V_{pk}$, $V_{IOSM} = 6875 V_{pk}$ (certification n. 40052310)
- IEC 60747-17 (certification n. 40055138)
- IEC62368-1 (certification n. 40052310, appendix 500Z1)

Product validation

Fully qualified for industrial applications

Table 1

Portfolio

Part number	UVLO	EN/DIS	Package
2EDR8259H	8 V	DIS	DSO16-300mil
2EDR7259X	4 V	DIS	DSO14-300mil
2EDR8259X	8 V	DIS	DSO14-300mil
2EDR9259X	15 V	DIS	DSO14-300mil
2EDR8258X	8 V	EN	DSO14-300mil
2EDR6258X	12 V	EN	DSO14-300mil
2EDR9258X	15 V	EN	DSO14-300mil

Potential applications

- Server, telecom SMPS
- EV Off-board chargers
- Low-voltage drives and power tools
- Solar micro inverter, solar optimizer
- Industrial power supply (SMPS, Residential UPS)

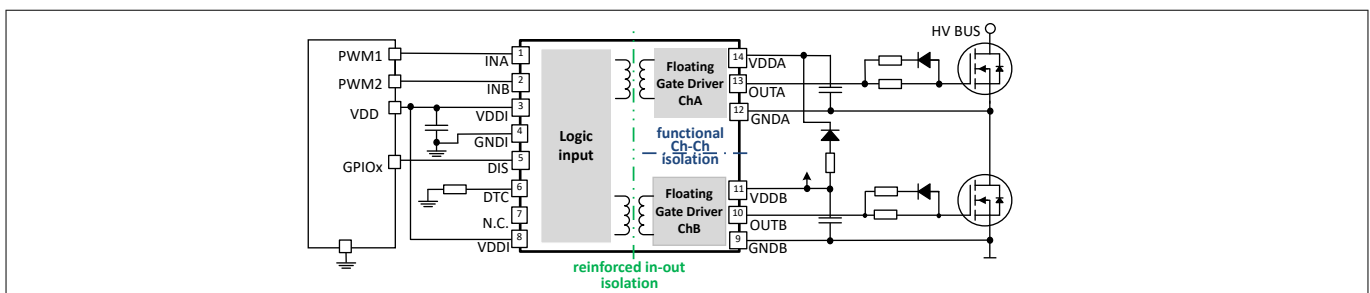

Figure 1 Application diagram

Table of contents

	Table of contents	2
1	Pin configuration and description	3
2	Functional description	5
2.1	Block diagram	5
2.2	Power supply and Undervoltage Lockout (UVLO)	5
2.2.1	Input supply voltage	5
2.2.2	Output supply voltage	5
2.3	Input stage - INA, INB, DISABLE	6
2.4	Shoot-through protection and configurable dead-time - STP/DTC	8
2.5	Gate driver outputs	9
2.6	Fast active output clamping in UVLO conditions	9
2.7	CT communication and input to output data transmission	9
3	Electrical characteristics	10
3.1	Absolute maximum ratings	10
3.2	Thermal characteristics	11
3.3	Operating range	12
3.4	Electrical characteristics	12
3.5	Isolation specifications	17
4	Timing diagrams	20
5	Typical characteristics	23
6	Package outline dimensions	29
6.1	Device numbers and markings	29
6.2	Package DSO16-300mil	29
6.3	Package DSO14-300mil	31
7	Revision history	33
	Disclaimer	34

1 Pin configuration and description

1 Pin configuration and description

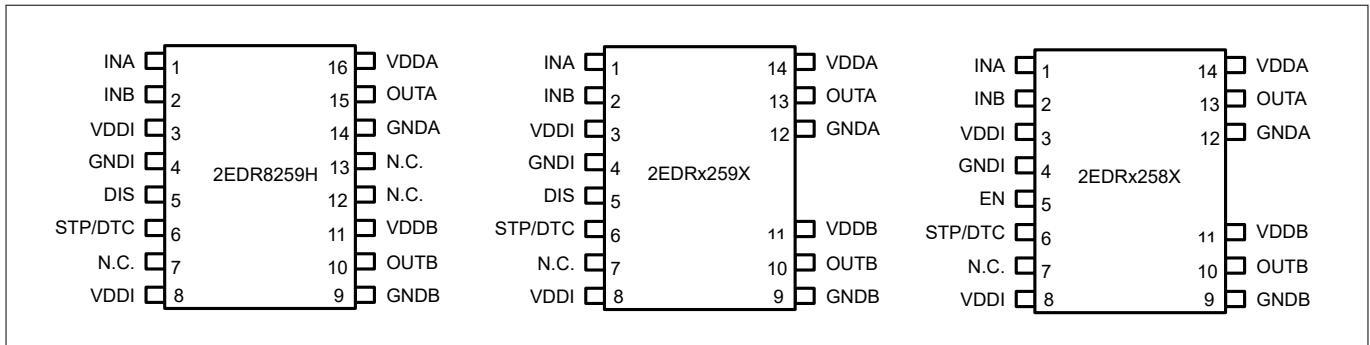

Figure 2 Pin configuration (top side view)

Table 2 Pin description

Pin 16-pin	Pin 14-pin	Symbol	Description
1	1	INA	Input signal channel A Logic input with TTL compatible thresholds and internal pull-down resistor
2	2	INB	Input signal channel B Logic input with TTL compatible thresholds and internal pull-down resistor
3,8	3,8	VDDI	Input-side supply voltage (operating range: 3 V to 17 V)
4	4	GNDI	Ground primary-side
5	5	DIS/ EN	Disable input channel A and B (active high) If DIS is low or left open, OUTA/OUTB are controlled by INA/INB DIS high causes OUTA/OUTB low ENABLE input channel A and B (active high) If EN is high, OUTA/OUTB are controlled by INA/INB EN low or left open causes OUTA/OUTB low
6	6	STP/DTC	Shoot-through Protection (STP) and Dead-Time Control (DTC) If STP/DTC is high or left open, OUTA and OUTB can overlap (SPT and DTC disabled). If STP/DTC is connected to GNDI with a resistance R_{DTC} , OUTA and OUTB cannot overlap and a “safe dead-time” can be configured: $t_{dt} [ns] = 10 \times R_{DTC} [k\Omega]$ If STP/DTC is connected to GNDI, OUTA and OUTB cannot overlap (STP only enabled) Connecting capacitors to the DTC pin must be avoided.
7,12,13	7	N.C.	No internal connection
9	9	GNDB	Ground secondary-side channel B
10	10	OUTB	Output secondary-side channel B Low-impedance output with source and sink capability
11	11	VDDB	Supply secondary-side channel B (operating range: UVLO to 20 V)

(table continues...)

1 Pin configuration and description

Table 2 (continued) **Pin description**

Pin 16-pin	Pin 14-pin	Symbol	Description
14	12	GNDA	Ground secondary-side channel A
15	13	OUTA	Output secondary-side channel A Low-impedance output with source and sink capability
16	14	VDDA	Supply secondary-side channel A (operating range: UVLO to 20 V)

For package drawing details see [Chapter 6](#).

2 Functional description

2 Functional description

2.1 Block diagram

A simplified functional block diagram for EiceDRIVER™ 2EDR8259H, 2EDRx259X is given in [Figure 3](#).

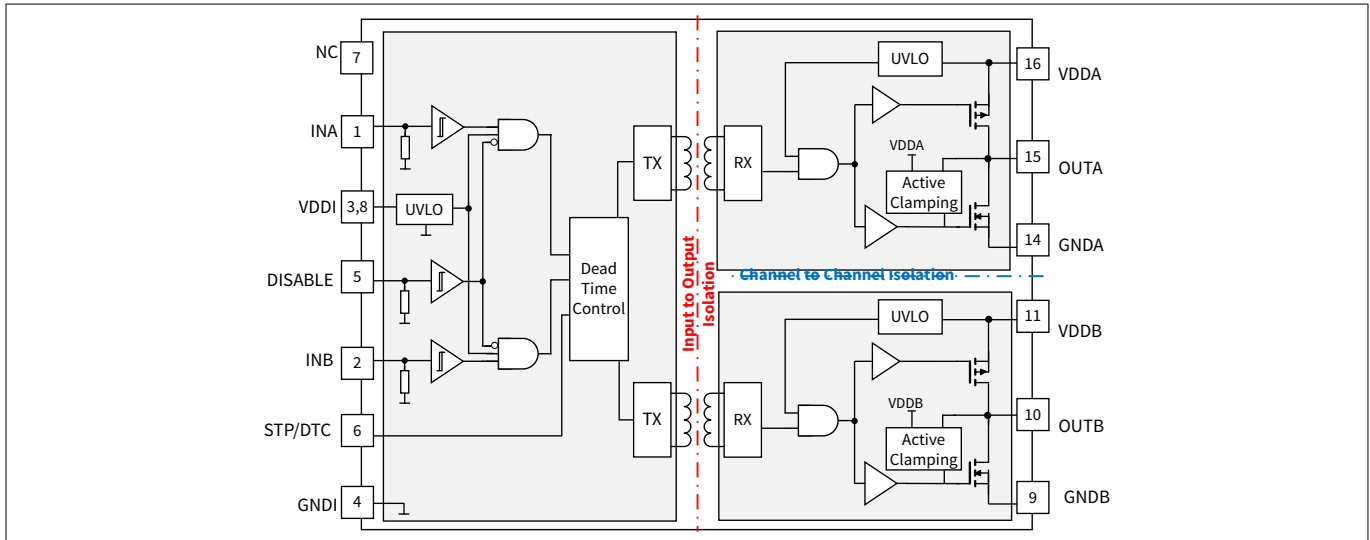

Figure 3 Block diagram

2.2 Power supply and Undervoltage Lockout (UVLO)

Due to the input-to-output and channel-to-channel isolation, three power domains with independent power management are required. Undervoltage Lockout (UVLO) functions for both input and output supplies ensure a defined startup and robust functionality under all operating conditions.

2.2.1 Input supply voltage

The input die is powered via VDDI and supports a wide supply voltage range from 3 V to 17 V. A ceramic bypass capacitor must be placed between VDDI and GNDI in close proximity to the device; a minimum bypass capacitance of 100 nF is recommended.

Power consumption to some extent, depends on switching frequency, as the input signal is converted into a train of repetitive current pulses to drive the coreless transformer. Due to the chosen robust encoding scheme the average repetition rate of these pulses and thus the average supply current depends on the switching frequency, f_{sw} . However, for $f_{sw} < 500$ kHz this effect is very small.

The Undervoltage Lockout function for the input supply V_{DDI} ensures that, as long as V_{DDI} is below UVLO (e.g. in startup), no data is transferred to the output side and the gate driver output is held low (safety Lock-down at startup). When V_{DDI} exceeds the UVLO level, the PWM input signal is transferred to the output side. If the output side is ready (not in UVLO condition), the output reacts according to the logic input.

2.2.2 Output supply voltage

The two output dies are powered via two independent supply voltages V_{DDA} and V_{DDB} (up to 20 V).

Two ceramic bypass capacitors must be placed between VDDA and GNDA and between VDDB and GNDB in close proximity to the device. A minimum capacitance of $20 \times C_{iss}$ (MOSFET input capacitance) is recommended to ensure an acceptable ripple (5% of V_{DDO}) on the supply pin.

The minimum supply voltage is set by the Undervoltage Lockout (UVLO) function. The gate driver output can be switched only if the output supply voltage (V_{DDA} , V_{DDB}) exceeds the output-side UVLO. Thus, it can be guaranteed that the switch transistor is not operated if the driving voltage is too low to achieve a complete and fast transition to the "on" state. Low driving voltage, in fact, could cause the power MOSFET to enter its saturation (ohmic) region with potentially destructive power dissipation; the output UVLO ensures that the

2 Functional description

switch transistor always stays within its Safe Operating Area (SOA). Versions with 4 V, 8 V, 12 V and 15 V UVLO thresholds for the output supply are currently available. [Table 3](#) shows the recommended UVLO levels for different Infineon power switch families.

Table 3 Recommended UVLO levels for typical use-cases

Inputs	Examples of part number	Recommended driver
Logic level OptiMOS™	BSC010N04LS6, BSZ070N08LS5, ..	2EDR7259 (4 V UVLO)
Normal level OptiMOS™	BSC040N10NS5, BSZ084N08NS5, ..	2EDR825x (8 V UVLO)
CoolMOS™	IPP60R099C7, IPB60R600P6, ..	2EDR825x (8 V UVLO)
650 V CoolSiC™	IMZA65R027M1H, IMW65R107M1H, ..	2EDR6258/ 2EDR925x (12/15 V UVLO)
650 V CoolGaN™	IGOT60R070D1, IGLD60R070D1, ..	2EDR7259 (4 V UVLO for unipolar driving) 2EDR825x (8 V UVLO for bipolar driving)

2.3 Input stage - INA, INB, DISABLE

The inputs INA and INB control two independent PWM channels. The input signal is transferred non-inverted to the corresponding gate driver outputs OUTA and OUTB. All inputs are compatible with LV-TTL threshold levels and provide a hysteresis of typically 0.8 V. The hysteresis is independent of the supply voltage V_{DDI} .

The PWM inputs are internally pulled down to a logic low voltage level (GNDI). In case the PWM-controller signals have an undefined state during the power-up sequence, the gate driver outputs are forced to the "off"-state (low).

If the DIS/EN input is at high/low state, this unconditionally drives both channel outputs to low state regardless of the state of INA or INB.

[Table 4](#) and [Table 5](#) shows the INA, INB, DIS/EN driver logic in case of sufficiently high supply voltage. Otherwise the outputs of the driver are determined by the Undervoltage Lockout (UVLO) and Output Active Clamping functionalities as shown in [Table 8](#).

Table 4 Logic table in case of sufficient bias power - INA, INB, DIS

Inputs		DIS	Supplies	Outputs		Note
INA	INB		V_{DDI} , V_{DDA} , V_{DDB}	OUTA	OUTB	
L	L	L or left open	> $UVLO_{VDDx,on}$ (active)	L	L	–
L	H	L or left open		L	H	–
H	H	L or left open		H	H	DTC/STP pin tied to V_{DDI} or left open
				L	L	DTC/STP pin tied to GNDI via R_{DTC}
Left open	Left open	L or left open		L	L	Input pins internally pulled down
x	x	H		L	L	Outputs disabled via DIS high

2 Functional description

Table 5 **Logic table in case of sufficient bias power - INA, INB, EN**

Inputs		EN	Supplies	Outputs		Note
INA	INB		V_{DDI} , V_{DDA} , V_{DDB}	OUTA	OUTB	
L	L	H	> $UVLO_{VDDx,on}$ (active)	L	L	–
L	H	H		L	H	–
H	H	H		H	H	DTC/STP pin tied to VDDI or left open
				L	L	DTC/STP pin tied to GNDI via R_{DTC}
Left open	Left open	H		L	L	Input pins internally pulled down
x	x	L or left open		L	L	Outputs disabled via EN low

2 Functional description

2.4 Shoot-through protection and configurable dead-time - STP/DTC

The shoot-through protection pulls down the outputs OUTA and OUTB when both input signals INA, INB are at high state. Its activation is recommended when the driver is used as half-bridge driver to prevent dangerous shoot-through due to unwanted overlap of INA and INB. A dead-time can be ensured and configured via pin STP/DTC as shown in Table 6.

Table 6 STP/DTC logic table

Conditions on the STP/DTC pin	Shoot-through protection	Configurable dead-time
Tied to VDDI or left open	Disabled	Disabled
Connected to GNDI via resistor R_{DTC}	Enabled	Enabled with $t_{dt} [ns] = 10 \times R_{DTC} [k\Omega]$; allowed R_{DTC} range is 1.2k Ω to 100k Ω
Connected to GNDI	Enabled	Disabled

The driver dead-time logic is triggered during the falling edge of an input and delays the rising transition of the other input. The delay is only assigned if the driver configured dead-time is longer than the inputs signals' own dead-time.

The dead-time can be configured by changing the current fed into the STP/DTC pin via an external resistance according to the formula: $t_{dt} [ns] = 10 \times R_{DTC} [k\Omega]$. It is recommended to use resistors with 1% accuracy in the 1.2 k Ω to 100 k Ω range. Connecting capacitors to the DTC pin must be avoided when the dead-time control functionality is used.

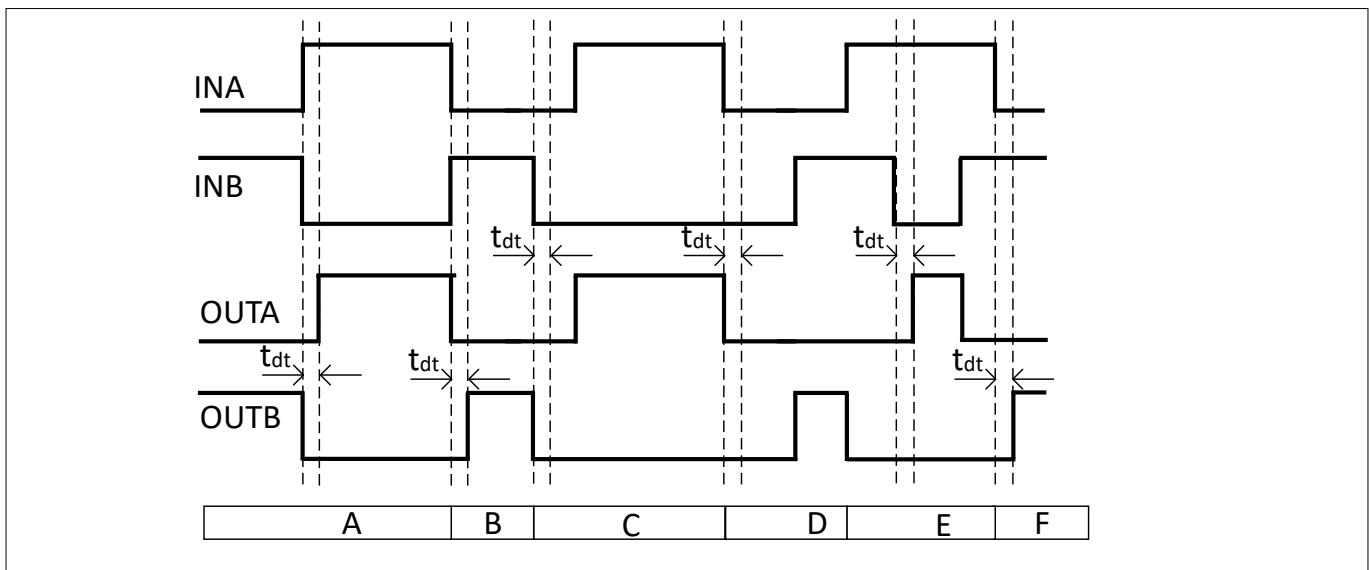

Figure 4 Logic for STP/DTC pin connected to GNDI via resistance R_{DTC}

Table 7 Logic for STP/DTC pin connected to GNDI via resistance R_{DTC}

Condition	STP/DTC logic
A, B	The driver logic assigns the configured dead-time since it is longer than the input signals' dead-time
C, D	The driver logic does not assign the configured dead-time since it is shorter than the input signals' dead-time

(table continues...)

2 Functional description

Table 7 (continued) Logic for STP/DTC pin connected to GNDI via resistance R_{DTC}

Condition	STP/DTC logic
E, F	The shoot-through protection pulls down the outputs OUTA, OUTB until one of the outputs goes low. At this point, after the configured driver dead-time, the other output is allowed to go high

2.5 Gate driver outputs

The rail-to-rail output stage realized with complementary MOS transistors is able to provide a typical 5 A sourcing and 9 A sinking peak current. The low on-resistance coming together with high driving current is particularly beneficial for fast switching of very large MOSFETs. With a R_{on} of $\sim 1 \Omega$ for the sourcing pMOS and $\sim 0.5 \Omega$ for the sinking nMOS transistor the driver can in most applications be considered as a nearly ideal switch. The p-channel sourcing transistor enables real rail-to-rail behavior without suffering from the voltage drop unavoidably associated with nMOS source follower stages.

In case of floating inputs or insufficient supply voltage not exceeding the UVLO thresholds, the driver outputs are actively clamped to the "low" level (GNDA, GNDB).

2.6 Fast active output clamping in UVLO conditions

The Undervoltage Lockout (UVLO) ensures that the gate driver output is not operated if the supplies are below the UVLO thresholds. However, this is not sufficient to guarantee that the output of the driver is kept low. Transients or noise in the power stage may pull-up the output node of the driver and the gate voltage causing an unwanted turn-on of the switch; this is particularly critical in system using bootstrapping since, during start-up, the supply of the high-side channel is delayed, while the low-side MOSFET is already switching. In resonant topologies (as LLC), the half-bridge switching node may be pulled up after the turn-off of the low-side switch. When the low-side MOSFET is turned on again, the high-side gate voltage increase induced by dV/dt event cannot be clamped by the driver $R_{DS(on),sink}$ if the bootstrap supply is not yet available.

With a fast output clamping circuit in the output stage, the driver ensures safe operation against output induced overshoots in all UVLO situations. This structure allows fast reaction and effective clamping of the output pins (OUTA, OUTB). The exact reaction time depends on the output supply (V_{DDA} , V_{DDB}) and on the output voltage levels; however, already for very low supply levels (~ 1 V), the active output clamp is able to react in some tens of ns.

Undervoltage Lockout together with the output active clamping ensures that the outputs are actively held low in case of insufficient supply voltages.

Table 8 Logic table in case of insufficient bias power - INA, INB, DISABLE

Inputs		DIS	Supplies			Outputs	
INA	INB		V_{DD}	V_{DDA}	V_{DDB}	OUTA	OUTB
X	X	X	$< UVLO_{VDDI,on}$	X	X	L	L
X	X	X	$> UVLO_{VDDI,on}$	$< UVLO_{VDDI,on}$	$< UVLO_{VDDI,on}$	L	L
X	X	X	$> UVLO_{VDDI,on}$	$> UVLO_{VDDI,on}$	$< UVLO_{VDDI,on}$	Follows INA	L
X	X	X	$> UVLO_{VDDI,on}$	$< UVLO_{VDDI,on}$	$> UVLO_{VDDI,on}$	L	Follows INB

2.7 CT communication and input to output data transmission

A coreless transformer (CT) based communication module is used for PWM signal transfer between input and output. A proven high-resolution pulse repetition scheme in the transmitter combined with a watchdog timeout at the receiver side enables recovery from communication fails and ensures safe system shut-down in failure cases.

3 Electrical characteristics

3 Electrical characteristics

The absolute maximum ratings are listed in Table 9. Stresses beyond these values may cause permanent damage to the device. Exposure to absolute maximum rating conditions for extended periods may affect device reliability.

3.1 Absolute maximum ratings

Table 9 Absolute maximum ratings

Parameter	Symbol	Values			Unit	Note or condition
		Min.	Typ.	Max.		
Input supply voltage	V_{DDI}	-0.3	–	18	V	–
Output supply voltage at pins VDDA, VDDB	V_{DDA}, V_{DDB}	-0.3	–	22 ¹⁾	V	–
Voltage at pins INA, INB, DIS/EN (DC)	V_{IN}	-0.3	–	18	V	–
Voltage at pins INA, INB, DIS/EN (transient)	V_{IN}	-5	–	–	V	transient for 50 ns ³⁾
Voltage at pin DTC	V_{DTC}	²⁾	–	$V_{DDI} + 0.3$	V	–
Voltage at pins OUTA, OUTB (DC)	V_{OUT}	-0.3	–	$V_{DDA/B} + 0.3$	V	–
Voltage at pins OUTA, OUTB (transient)	V_{OUT}	-2	–	$V_{DDA/B} + 1.5$	V	transient for 200 ns ³⁾
Reverse current peak at pins OUTA, OUTB	I_{SRC_rev}	-5	–	–	A_{pk}	transient for 500 ns ³⁾
Reverse current peak at pins OUTA, OUTB	I_{SNK_rev}	–	–	5	A_{pk}	transient for 500 ns ³⁾
Junction temperature	T_J	-40	–	150	°C	–
Storage temperature	T_{STG}	-65	–	150	°C	–
Soldering temperature	T_{SOL}	–	–	260	°C	reflow ⁴⁾
ESD capability	V_{ESD_CDM}	–	–	0.5	kV	Charged Device Model (CDM) ⁵⁾
ESD capability	V_{ESD_HBM}	–	–	2	kV	Human Body Model (HBM) ⁶⁾

- 1) Maximum positive supply voltage already complies with derating guidelines.
- 2) Minimum is given by internal regulation when DTC is operating (DTC pin connected to GND via resistance).
- 3) Not subject to production test - verified by design/characterization.
- 4) According to JEDEC-020E.
- 5) According to ANSI/ESDA/JEDEC JS-002.
- 6) According to ANSI/ESDA/JEDEC JS-001 (discharging 100 pF capacitor through 1.5 kΩ resistor).

3 Electrical characteristics

3.2 Thermal characteristics

Thermal characteristics are obtained from simulation with 65 mW applied to the driver input-side and 200 mW applied to any output channel.

Table 10 Thermal characteristics at $T_A = 25^\circ\text{C}$

Parameter	Symbol	Value		Unit	Note or condition
		1s0p ¹⁾	2s2p ²⁾		
Thermal resistance junction-case (top) ³⁾	R_{thJC}	46	46	K/W	–
Thermal resistance junction ambient ⁴⁾	R_{thJA25}	107	69	K/W	–
	R_{thJA85}	95	65	K/W	–
Thermal resistance junction board ⁵⁾	R_{thJB}	–	27	K/W	–
Characterization parameter junction-top ⁶⁾	Ψ_{thJT}	11	10	K/W	–
Characterization parameter junction-board ⁶⁾	Ψ_{thJB25}	21	23	K/W	–

- 1) Two-layer board as specified in JESD51-3 JEDEC-standard: no copper planes and no thermal vias for cooling, "package-alone" parameters
- 2) High-K board as specified in JESD51-7 JEDEC-standard: four-layers board with 2-oz inner layers copper planes and with no thermal vias for cooling
- 3) Obtained by simulating a cold plate test on the package top. No specific JEDEC standard exists, but a close description can be found in the ANSI SEMI standard G30-88
- 4) Obtained by simulating a JEDEC-standard, high-K board, as specified in JESD51-7, in an environment described in JESD51-2
- 5) Obtained by simulating a JEDEC-standard high-K board, as specified in JESD51-7, in an environment described in JESD51-8 with a ring cold plate fixture to control the PCB temperature
- 6) Estimates the junction temperature of a device in a real system and is extracted from the simulation data for obtaining Rth, using a procedure described in JESD51-2a (sections 6 and 7)

3 Electrical characteristics

3.3 Operating range

Table 11 Operating range

Parameter	Symbol	Values			Unit	Note or condition
		Min.	Typ.	Max.		
Input supply voltage at pin VDDI	V_{DDI}	3	–	17	V	Min. defined by $UVLO_{VDDI}$
Output supply voltage at pin VDDA and VDDB	V_{DDA}, V_{DDB}	4.5	–	20 ¹⁾	V	4 V UVLO option
Output supply voltage at pin VDDA and VDDB	V_{DDA}, V_{DDB}	8.5	–	20 ¹⁾	V	8 V UVLO option
Output supply voltage at pin VDDA and VDDB	V_{DDA}, V_{DDB}	12.9	–	20 ¹⁾	V	12 V UVLO option
Output supply voltage at pin VDDA and VDDB	V_{DDA}, V_{DDB}	15.6	–	20 ¹⁾	V	15 V UVLO option
Input voltage at pins INA, INB, DIS/EN	V_{IN}	0	–	17	V	–
Input voltage at pin DTC	V_{DTC}	²⁾	–	V_{DDI}	V	–
Junction temperature	T_J	-40	–	150 ³⁾	°C	
Ambient temperature	T_A	-40	–	125	°C	–

- 1) Maximum positive supply voltage already complies with derating guidelines.
 2) Minimum is given by internal regulation when DTC is operating (DTC pin connected to GND via resistance).
 3) Continuous operation above 125°C may reduce lifetime.

3.4 Electrical characteristics

Unless otherwise noted, the electrical characteristics are given for $V_{DDI} = 3.3$ V, $V_{DDA/B} = 12$ V and no load. Typical values are given at $T_J = 25^\circ\text{C}$ whilst min. and max., instead, are the lower and upper limits, respectively, within the full operating range.

Table 12 Power supply

Parameter	Symbol	Values			Unit	Note or condition
		Min.	Typ.	Max.		
IVDDI quiescent current	I_{VDDIq}	–	1.67	2.12	mA	no switching
IVDDA/B quiescent current	$I_{VDDA/Bq}$	–	0.62	0.86	mA	OUT = low, $V_{DDA/B} = 12$ V
IVDDA/B quiescent current	$I_{VDDA/Bq}$	–	0.66	0.89	mA	OUT = low, $V_{DDA/B} = 18$ V
IVDDA/B quiescent current	$I_{VDDA/Bq}$	–	0.76	1.0	mA	OUT = high, $V_{DDA/B} = 12$ V
IVDDA/B quiescent current	$I_{VDDA/Bq}$	–	0.9	1.14	mA	OUT = high, $V_{DDA/B} = 18$ V

3 Electrical characteristics

Table 13 Undervoltage Lockout VDDI

Parameter	Symbol	Values			Unit	Note or condition
		Min.	Typ.	Max.		
Undervoltage Lockout (UVLO) turn-on threshold VDDI	UVLO _{VDDI,on}	–	2.85	2.95	V	–
Undervoltage Lockout (UVLO) turn-off threshold VDDI	UVLO _{VDDI,off}	2.55	2.7	–	V	–
UVLO threshold hysteresis VDDI	UVLO _{VDDI,hys}	0.10	0.15	0.20	V	–

Table 14 Undervoltage Lockout VDDA, VDDB for 4 V UVLO option

Parameter	Symbol	Values			Unit	Note or condition
		Min.	Typ.	Max.		
Undervoltage Lockout (UVLO) turn-on threshold VDDA, VDDB	UVLO _{VDDA,on} UVLO _{VDDB,on}	–	4.2	4.4	V	–
Undervoltage Lockout (UVLO) turn-off threshold VDDA, VDDB	UVLO _{VDDA,off} UVLO _{VDDB,off}	3.7	3.9	–	V	–
UVLO threshold hysteresis VDDA, VDDB	UVLO _{VDDA,hys} UVLO _{VDDB,hys}	0.2	0.3	0.4	V	–

Table 15 Undervoltage Lockout VDDA, VDDB for 8 V UVLO option

Parameter	Symbol	Values			Unit	Note or condition
		Min.	Typ.	Max.		
Undervoltage Lockout (UVLO) turn-on threshold VDDA, VDDB	UVLO _{VDDA,on} UVLO _{VDDB,on}	–	8.0	8.5	V	–
Undervoltage Lockout (UVLO) turn-off threshold VDDA, VDDB	UVLO _{VDDA,off} UVLO _{VDDB,off}	6.6	7.0	–	V	–
UVLO threshold hysteresis VDDA, VDDB	UVLO _{VDDA,hys} UVLO _{VDDB,hys}	0.7	1	1.3	V	–

3 Electrical characteristics

Table 16 Undervoltage Lockout VDDA, VDDB for 12 V UVLO option

Parameter	Symbol	Values			Unit	Note or condition
		Min.	Typ.	Max.		
Undervoltage Lockout (UVLO) turn-on threshold VDDA, VDDB	UVLO _{VDDA,on} UVLO _{VDDB,on}	–	12.2	12.8	V	–
Undervoltage Lockout (UVLO) turn-off threshold VDDA, VDDB	UVLO _{VDDA,off} UVLO _{VDDB,off}	10.8	11.5	–	V	–
UVLO threshold hysteresis VDDA, VDDB	UVLO _{VDDA,hys} UVLO _{VDDB,hys}	0.5	0.7	0.9	V	–

Table 17 Undervoltage Lockout VDDA, VDDB for 15 V UVLO option

Parameter	Symbol	Values			Unit	Note or condition
		Min.	Typ.	Max.		
Undervoltage Lockout (UVLO) turn-on threshold VDDA, VDDB	UVLO _{VDDA,on} UVLO _{VDDB,on}	–	14.9	15.5	V	–
Undervoltage Lockout (UVLO) turn-off threshold VDDA, VDDB	UVLO _{VDDA,off} UVLO _{VDDB,off}	13.7	14.4	–	V	–
Duplicate of UVLO threshold hysteresis VDDA, VDDB	UVLO _{VDDA,hys} UVLO _{VDDB,hys}	0.3	0.5	0.7	V	–

Table 18 Logic inputs INA, INB, DISABLE

Parameter	Symbol	Values			Unit	Note or condition
		Min.	Typ.	Max.		
Input voltage threshold for transition LH	V _{INH}	–	2.0	2.36	V	–
Input voltage threshold for transition HL	V _{INL}	0.9	1.2	–	V	–
Input voltage threshold hysteresis	V _{IN,hys}	0.38	0.8	1.2	V	–
High-level input leakage current	I _{IN}	–	22	27	μA	INA/INB pin tied to VDDI
Input pull-down resistor	R _{IN,PD}	–	150	–	kΩ	–

3 Electrical characteristics

Table 19 Dead-time control (DTC) and shoot-through protection (STP)

Parameter	Symbol	Values			Unit	Note or condition
		Min.	Typ.	Max.		
Dead-time	t_{dt}	85	100	115	ns	$R_{DTC} = 10\text{ k}\Omega$
Dead-time	t_{dt}	255	300	345	ns	$R_{DTC} = 30\text{ k}\Omega$
Dead-time	t_{dt}	800	950	1100	ns	$R_{DTC} = 100\text{ k}\Omega$ ¹⁾
Channel-to-channel dead-time mismatch	$\Delta t_{dt,Ch-Ch}$	0	–	10	ns	$R_{DTC} = 10\text{ k}\Omega$
Channel-to-channel dead-time mismatch	$\Delta t_{dt,Ch-Ch}$	0	–	14	ns	$R_{DTC} = 30\text{ k}\Omega$
Channel-to-channel dead-time mismatch	$\Delta t_{dt,Ch-Ch}$	0	–	40	ns	$R_{DTC} = 100\text{ k}\Omega$ ¹⁾
Part-to-part dead-time mismatch	$\Delta t_{dt,p-p}$	0	–	20	ns	$R_{DTC} = 10\text{ k}\Omega$ ²⁾
Part-to-part dead-time mismatch	$\Delta t_{dt,p-p}$	0	–	55	ns	$R_{DTC} = 30\text{ k}\Omega$ ²⁾
Part-to-part dead-time mismatch	$\Delta t_{dt,p-p}$	0	–	105	ns	$R_{DTC} = 100\text{ k}\Omega$ ^{1) 2)}

1) Not subject to production test - verified by design/characterization.

2) The parameter gives the difference in the dead-time inserted from different samples under the same conditions, including same ambient temperature.

Table 20 Static output characteristics

Parameter	Symbol	Values			Unit	Note or condition
		Min.	Typ.	Max.		
High-level (sourcing) output resistance	R_{on_SRC}	0.6	0.95	1.5	Ω	$I_{SRC} = 50\text{ mA}$
Peak sourcing output current	I_{SRC_pk}	–	5	–	A	$C_{LOAD} = 22\text{ nF}$ ¹⁾
Low-level (sinking) output resistance	R_{on_SNK}	0.24	0.39	0.62	Ω	$I_{SNK} = 50\text{ mA}$
Peak sinking output current	I_{SNK_pk}		-9	–	A	$C_{LOAD} = 22\text{ nF}$ ¹⁾

1) Not subject to production test - verified by design/characterization.

Table 21 Dynamic characteristics

Parameter	Symbol	Values			Unit	Note or condition
		Min.	Typ.	Max.		
INx to OUTx turn-on propagation delay	$t_{pDon,INx}$	33	38	47	ns	See Figure 5 , Figure 6

(table continues...)

3 Electrical characteristics

Table 21 (continued) Dynamic characteristics

Parameter	Symbol	Values			Unit	Note or condition
		Min.	Typ.	Max.		
INx to OUTx turn-off propagation delay	$t_{PDoff,INx}$	30	36	46	ns	See Figure 5 , Figure 6
Part-to-part turn-on propagation delay mismatch	$\Delta t_{PDon,p-p}$	0	–	6	ns	¹⁾
Part-to-part turn-off propagation delay mismatch	$\Delta t_{PDoff,p-p}$	0	–	8	ns	¹⁾
Channel-to-channel turn-on propagation delay mismatch	$t_{PDon,ChA-ChB}$	-4	–	4	ns	²⁾ See Figure 7
Channel-to-channel turn-off propagation delay mismatch	$\Delta t_{PDoff,ChA-ChB}$	-5.5	–	3	ns	²⁾ See Figure 7
Pulse width distortion	t_{PWD}	-5	2	5.5	ns	³⁾ See Figure 8
Channel turn-off to channel turn-on propagation delay mismatch	t_{DTD}	-5	-2	1	ns	^{4) 5)} See Figure 9
Rise time	t_{rise}	–	7.5	14	ns	⁶⁾ $C_{LOAD} = 1.8$ nF, see Figure 10
Fall time	t_{fall}	–	6	11	ns	⁶⁾ $C_{LOAD} = 1.8$ nF, see Figure 10
Minimum input pulse width that changes output state	t_{PW}	10	17	25	ns	See Figure 11
Input-side start-up time	$t_{START,VDDI}$	–	3.5	5	μ s	⁶⁾ see Figure 12
Input-side deactivation time	$t_{STOP,VDDI}$	600	750	–	ns	⁶⁾ see Figure 12
Output-side start-up time	$t_{START,VDDA/B}$	–	2.5	5	μ s	⁶⁾ see Figure 13
Output-side deactivation time	$t_{STOP,VDDA/B}$	500	800	–	ns	⁶⁾ see Figure 13

- 1) The parameter gives the difference in the propagation delay between different samples switching in the same direction under same conditions, including same ambient temperature; therefore, is an indication of the production spread. The limits given are valid for all channels combination: $t_{PD_ChA} - t_{PD_ChA}$, $t_{PD_ChB} - t_{PD_ChB}$, $t_{PD_ChA} - t_{PD_ChB}$, $t_{PD_ChB} - t_{PD_ChA}$.
- 2) The parameter gives the difference in the propagation delay of channel A and channel B switching in the same direction in the same sample.
- 3) The parameter gives the difference between ON and OFF propagation delay in the same channel (ChA or ChB), in the same sample at same ambient temperature.

3 Electrical characteristics

- 4) The parameter gives the difference between the ON propagation delay of one channel and the OFF propagation delay of the other channel, in the same sample at same room temperature. This parameter represents the distortion of the inputs dead-time only when the driver DTC is not used or not enforced otherwise, please refer to [Table 19](#).
- 5) Not subject to production test - verified by characterization.
- 6) Not subject to production test - verified by design/characterization.

Table 22 Common-Mode Transient Immunity (CMTI)

Parameter	Symbol	Values			Unit	Note or condition
		Min.	Typ.	Max.		
Static Common-Mode Transient Immunity	$ CM_{Static,H} $	150	–	–	V/ns	$V_{CM} = 1500\text{ V}$; INA, INB tied to V_{DDI} (logic high inputs) ¹⁾
Static Common-Mode Transient Immunity	$ CM_{Static,L} $	150	–	–	V/ns	$V_{CM} = 1500\text{ V}$; INA, INB tied to GNDI (logic low inputs) ¹⁾

1) Minimum slew rate of a common-mode voltage that is able to cause an incorrect output signal

3.5 Isolation specifications

Table 23 Isolation specifications

Parameter	Symbol	Value	Unit	Note or condition
External input-to-output creepage ¹⁾	CRP	8	mm	Shortest distance over package surface from any input pin to any output pin according to IEC 60664-1
External input-to-output clearance ¹⁾	CLR	8	mm	Shortest distance in air from any input pin to any output pin according to IEC 60664-1
Comparative tracking index	CTI	> 400	V	According to DIN EN 60112 (VDE 0303-11)
Material group	–	II	–	According to IEC 60112
Pollution degree	–	II	–	According to IEC 60664-1
Overvoltage category (for reinforced isolation)	–	I - IV	–	Rated mains voltage $\leq 150\text{ V}_{RMS}$
	–	I - IV	–	Rated mains voltage $\leq 300\text{ V}_{RMS}$
	–	I - III	–	Rated mains voltage $\leq 600\text{ V}_{RMS}$

Input-to-output isolation according to UL1577 Ed.5 ²⁾

Input-to-output isolation voltage	V_{ISO}	5700	V_{RMS}	$V_{TEST} = V_{ISO}$ for $t = 60\text{ s}$ (qualification); $V_{TEST} = 1.2 \times V_{ISO}$ for $t = 1\text{ s}$ (100% productive tests)
-----------------------------------	-----------	------	-----------	---

Input-to-output isolation according to DIN VDE V0884-11 ³⁾ and IEC 60747-17 ⁴⁾

Maximum impulse voltage	V_{IMP}	8000	V_{pk}	According to IEC 60664-1
Maximum rated transient isolation voltage	V_{IOTM}	8000	V_{pk}	$V_{TEST} = V_{IOTM}$ for $t_{ini} = 60\text{ s}$ (type tests and quarterly monitoring) $V_{TEST} = 1.2 \times V_{IOTM}$ for $t_{ini} = 1\text{ s}$ (100% productive tests)

(table continues...)

3 Electrical characteristics

Table 23 (continued) Isolation specifications

Parameter	Symbol	Value	Unit	Note or condition
Maximum rated repetitive isolation voltage	V_{IORM}	1767	V_{pk}	According to Time Dependent Dielectric Breakdown (TDDb) Test for reinforced isolation
Apparent charge	q_{PD}	< 5	pC	$V_{ini,b1} = 1.2 \times V_{IOTM}$ (100% productive tests) and $V_{ini,b1} = V_{IOTM}$ (type tests preconditioning) for $t_{ini} = 1s$ $V_{pd(m)} = 1.875 \times V_{IORM}$ for $t_m = 1 s$ ⁵⁾
				After subgroup 1 life tests (type test) and in quarterly monitoring $V_{ini,a} = V_{IOTM}$ for $t_{ini} = 60 s$ $V_{pd(m)} = 1.6 \times V_{IORM}$ for $t_m = 10 s$
				After subgroup 2, 3 endurance tests (type test) $V_{ini,a} = V_{IOTM}$ for $t_{ini} = 60 s$ $V_{pd(m)} = 1.2 \times V_{IORM}$ for $t_m = 10 s$
Maximum surge isolation voltage ⁶⁾	V_{IOSM}	6875	V_{pk}	$V_{IOSM_TEST} = 1.6 \times V_{IOSM}$ for reinforced isolation according VDE 0884-11
		11000	V_{pk}	$V_{IOSM_TEST} = 11 kV_{pk} \geq 1.3 \times V_{IOSM}$ for reinforced isolation according IEC 60747-17
Isolation resistance input-to-output ⁷⁾	R_{IO}	10^{12}	Ω	$V_{IO} = 500 V_{dc}$ for $t = 60 s$, $T_A = 25^\circ C$ (type tests subgroup 1)
		10^{11}	Ω	$V_{IO} = 500 V_{dc}$ for $t = 60 s$, $T_A = 125^\circ C$ (type tests preconditioning, type test subgroup 4 and quarterly monitoring)
		10^9	Ω	$V_{IO} = 500 V_{dc}$ for $t = 60 s$, $T_A = 25^\circ C$ (type tests subgroup 1, 2, 3) or $T_A = T_S$ (type tests subgroup 4 and quarterly monitoring)
Capacitance input-to-output ⁷⁾	C_{IO}	2	pF	$f = 1 MHz$

1) Creepage and clearance requirements depend on the application and related end-equipment isolation standard. Care should be taken to keep the required creepage and clearance value on printed-circuit-board level.

2) See UL 1577 certificate n. E311313.

3) See VDE 0884-11 certificate n. 40052310.

4) See IEC 60747-17 certificate n. 40055138.

5) The partial discharge voltage $VPD(m)$ applied during production tests is greater ($4411 V_{pk} > 1.875 \times V_{IORM}$) to include the F4 factor required by end equipment standards IEC 60664-1, IEC 62368-1 ($VPD(m) = F1 \times F2 \times F3 \times F4 \times V_{IORM} = 1.875 \times F4 \times V_{IORM}$).

6) The surge test is performed in insulation oil to determine the intrinsic surge immunity of the insulation barrier.

7) The parameters apply to the product converted in a two terminals device with all terminals on side 1 connected together and all terminals on side 2 connected together.

3 Electrical characteristics

Table 24 Output channel-to-channel isolation specifications

Parameter	Symbol	Value	Unit	Note or condition
External channel-to-channel creepage ¹⁾	CRP _{Ch-Ch, 14pin}	3.3	mm	Shortest distance over package surface between any output channel A pin and any output channel B pin
	CRP _{Ch-Ch, 16pin}	2.5	mm	

1) Creepage and clearance requirements depend on the application and related end-equipment isolation standard. Care should be taken to keep the required creepage and clearance value on printed-circuit-board level

4 Timing diagrams

4 Timing diagrams

Figure 5 illustrates the input-to-output propagation delays as observed at the capacitively loaded output.

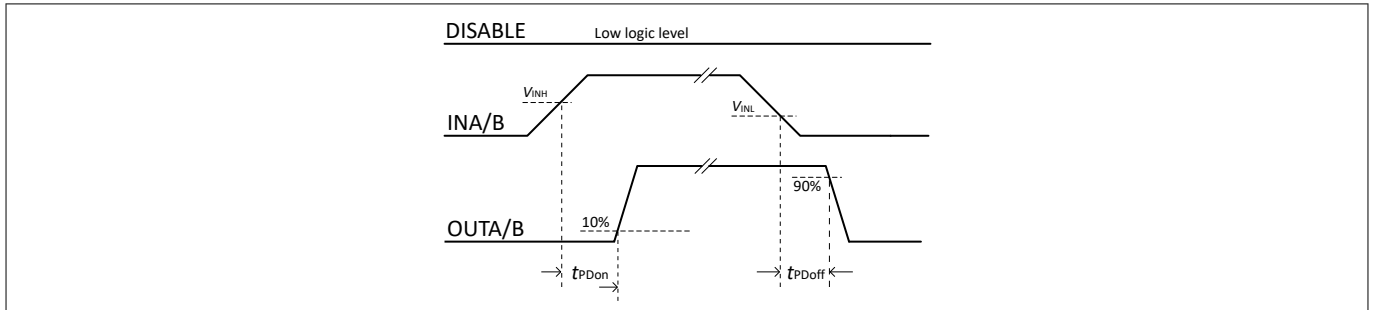

Figure 5 INx to OUTx propagation delays

Figure 6 illustrates the disable-to-output propagation delays as observed at the capacitively loaded output.

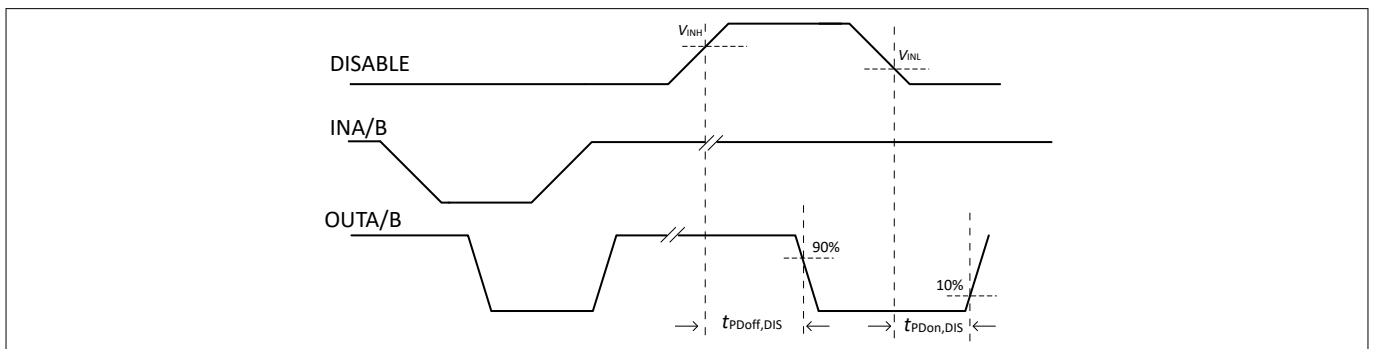

Figure 6 DISABLE to OUTx propagation delays

Figure 7 illustrates the channel-to-channel propagation delay mismatch at the unloaded outputs. This parameter is relevant when the channels drive parallel switches as it represents the delay in the two driving signals.

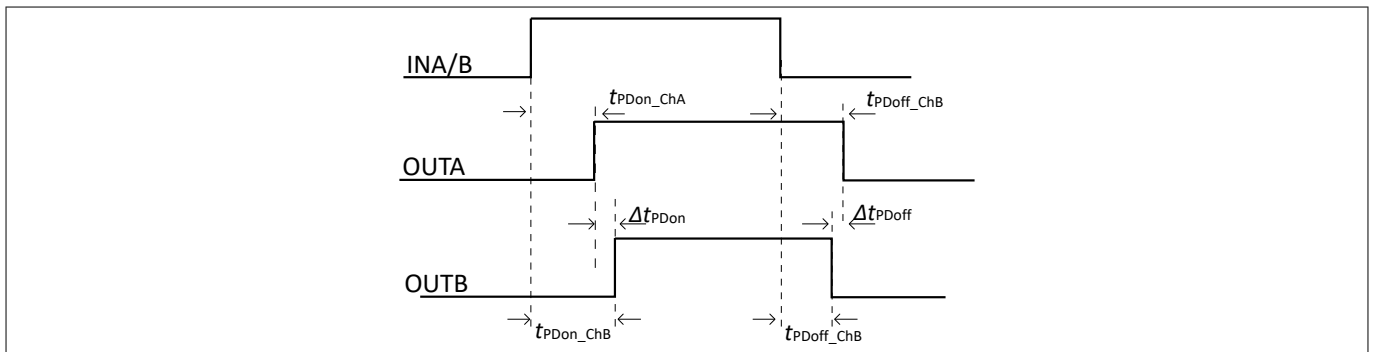

Figure 7 Channel-to-channel propagation delay mismatch

Figure 8 illustrates the pulse width distortion at the unloaded output. Ideally the width of the input pulse (t_{PW_INx}) equals the width of the output pulse (t_{PW_OUTx}); however, the driver introduces an output pulse distortion t_{PW} given by the difference between ON and OFF propagation delay.

4 Timing diagrams

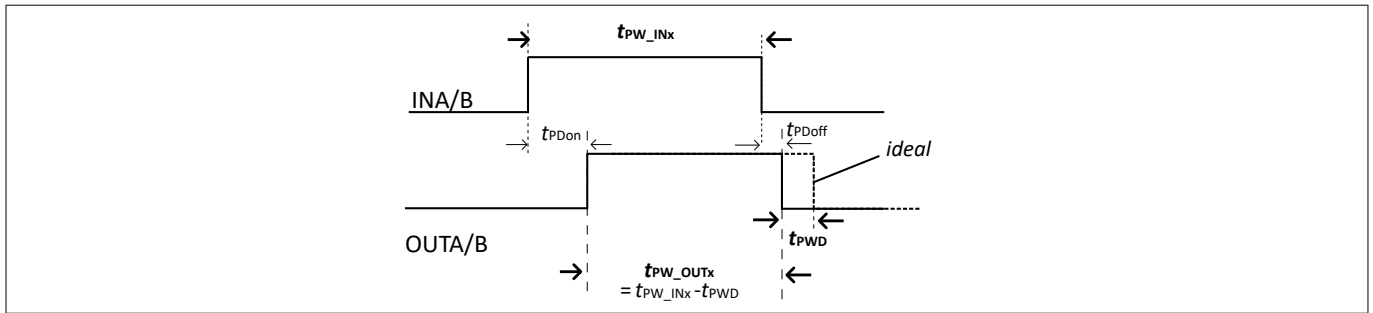

Figure 8 Pulse width distortion

Figure 9 illustrates the dead-time distortion at the unloaded outputs. This parameter is relevant in operation with complementary signals, as for the half-bridge driving when a certain dead-time t_{DT_INx} is set on the inputs INA, INB. Ideally the dead-time on the driver output (t_{DT_OUTx}) equals the input dead-time; however, the driver introduces a distortion t_{DTc} given by the difference between the OFF propagation delay of one channel and the ON propagation delay of the other channel.

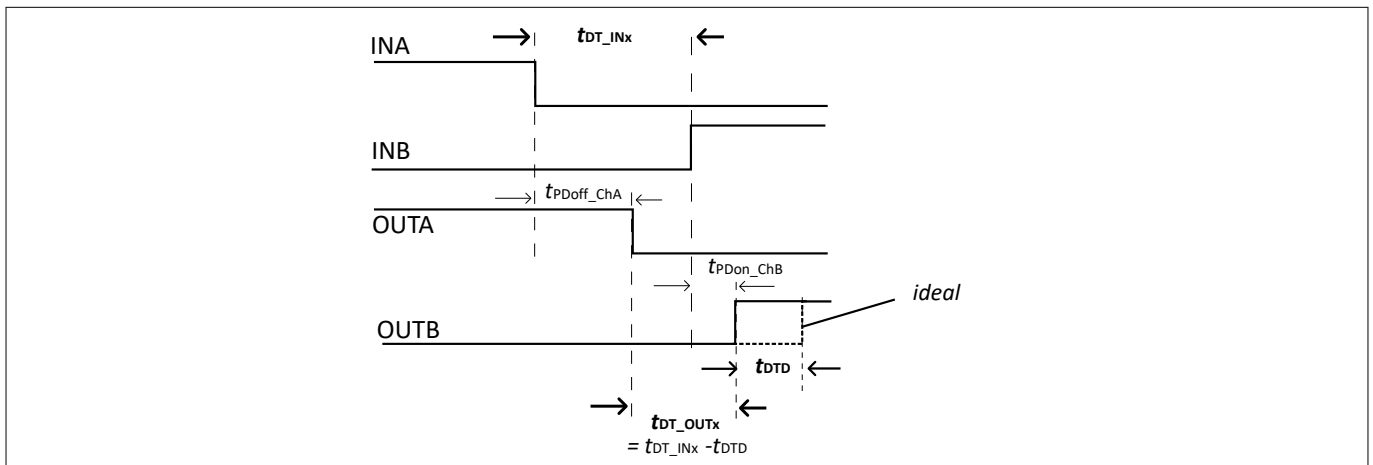

Figure 9 Channel turn-off to channel turn-on propagation delay mismatch

Figure 10 illustrates the rise and fall time as observed at the capacitively loaded output.

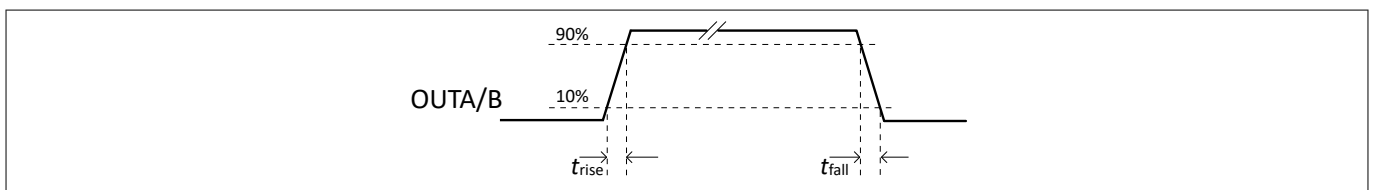

Figure 10 Rise and fall time

Figure 8 illustrates the behavior of the deglitch filter that filters spurious pulses on INA, INB with duration shorter than t_{PWmin} .

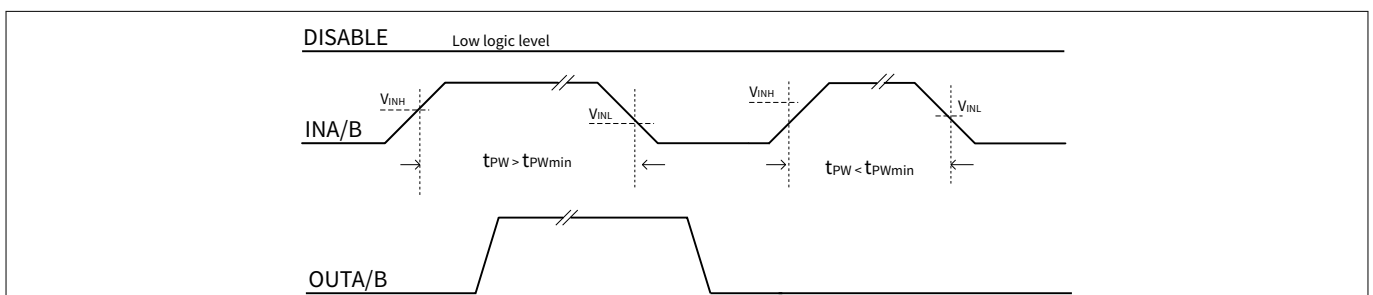

Figure 11 Minimum pulse that changes the output state

4 Timing diagrams

Figure 12 illustrates the input-side supply UVLO behavior. It depicts the reaction time to UVLO events when V_{DDI} crosses the UVLO thresholds during rising or falling transitions (power-up, power-down, supply noise).

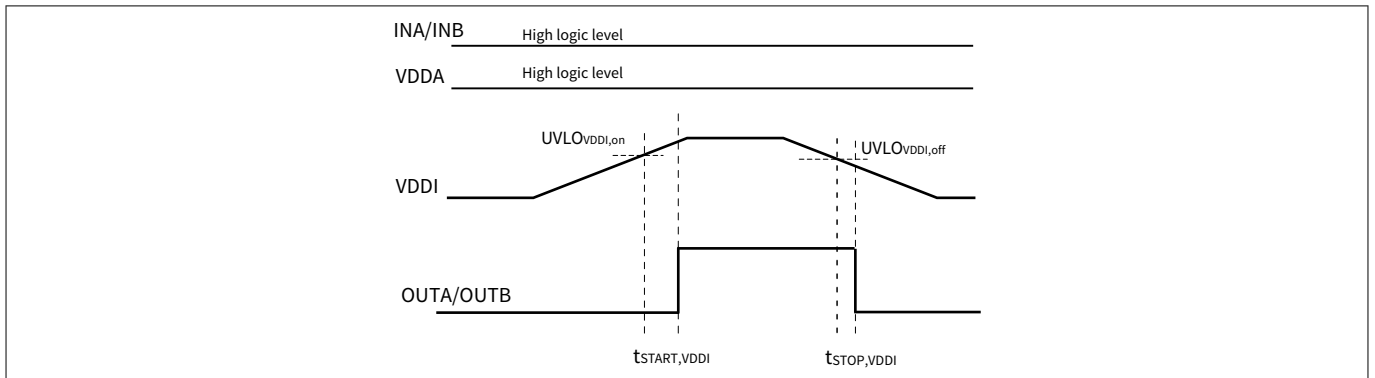

Figure 12 V_{DDI} UVLO behavior, start-up and deactivation time

Figure 13 illustrates the output-side supply UVLO behavior. It depicts the reaction time to UVLO events when $V_{DDA/B}$ crosses the UVLO thresholds during rising or falling transitions (power-up, power-down, supply noise).

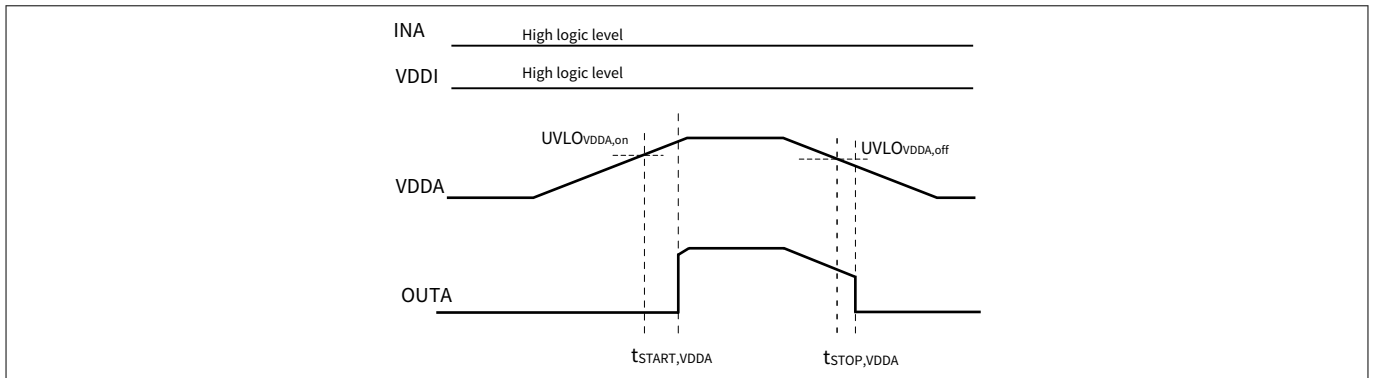

Figure 13 V_{DDA}, V_{DDB} UVLO behavior, start-up and deactivation time

Figure 14 illustrates the shoot-through protection and dead-time logic. When enabled, the dead-time is added on top of the turn-off propagation delay if the driver dead-time is longer than the signals' own dead-time.

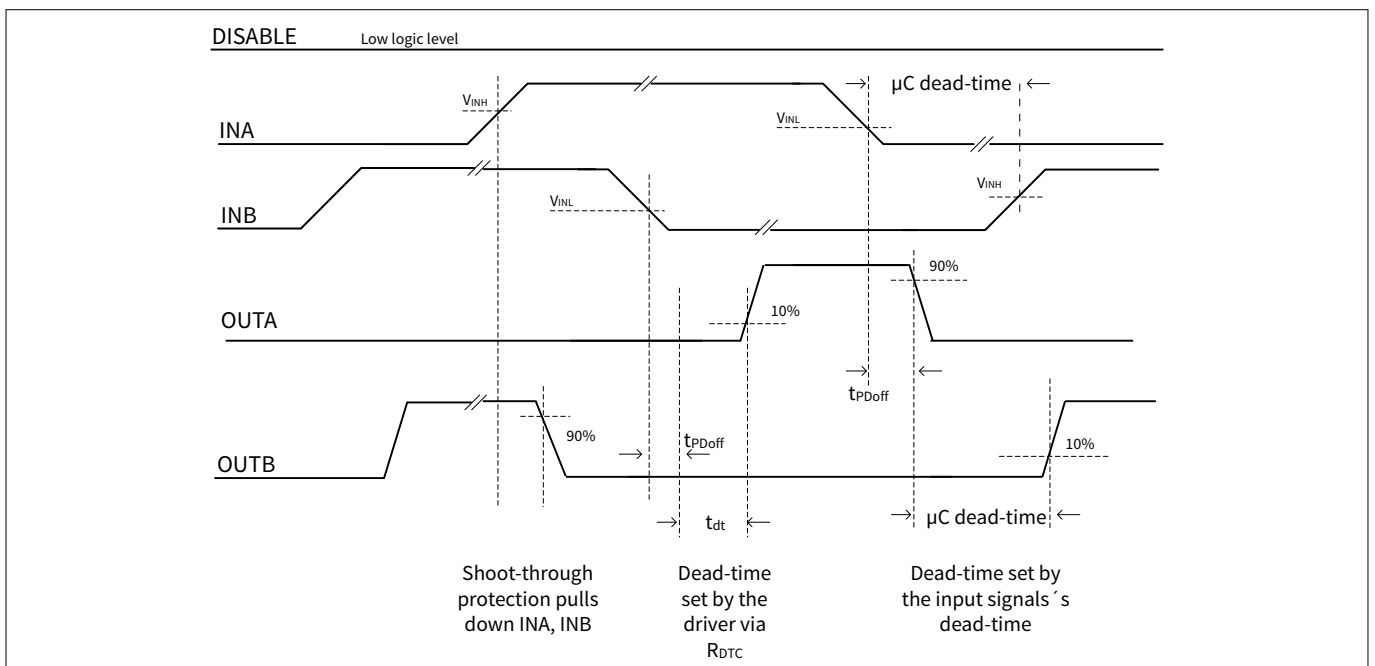

Figure 14 Shoot-through and configurable dead-time

5 Typical characteristics

5 Typical characteristics

$V_{DDI} = 3.3\text{ V}$, $V_{DDA/B} = 12\text{ V}$, $T_A = 25^\circ\text{C}$, $f_{sw} = 1\text{ MHz}$, no load unless otherwise noted

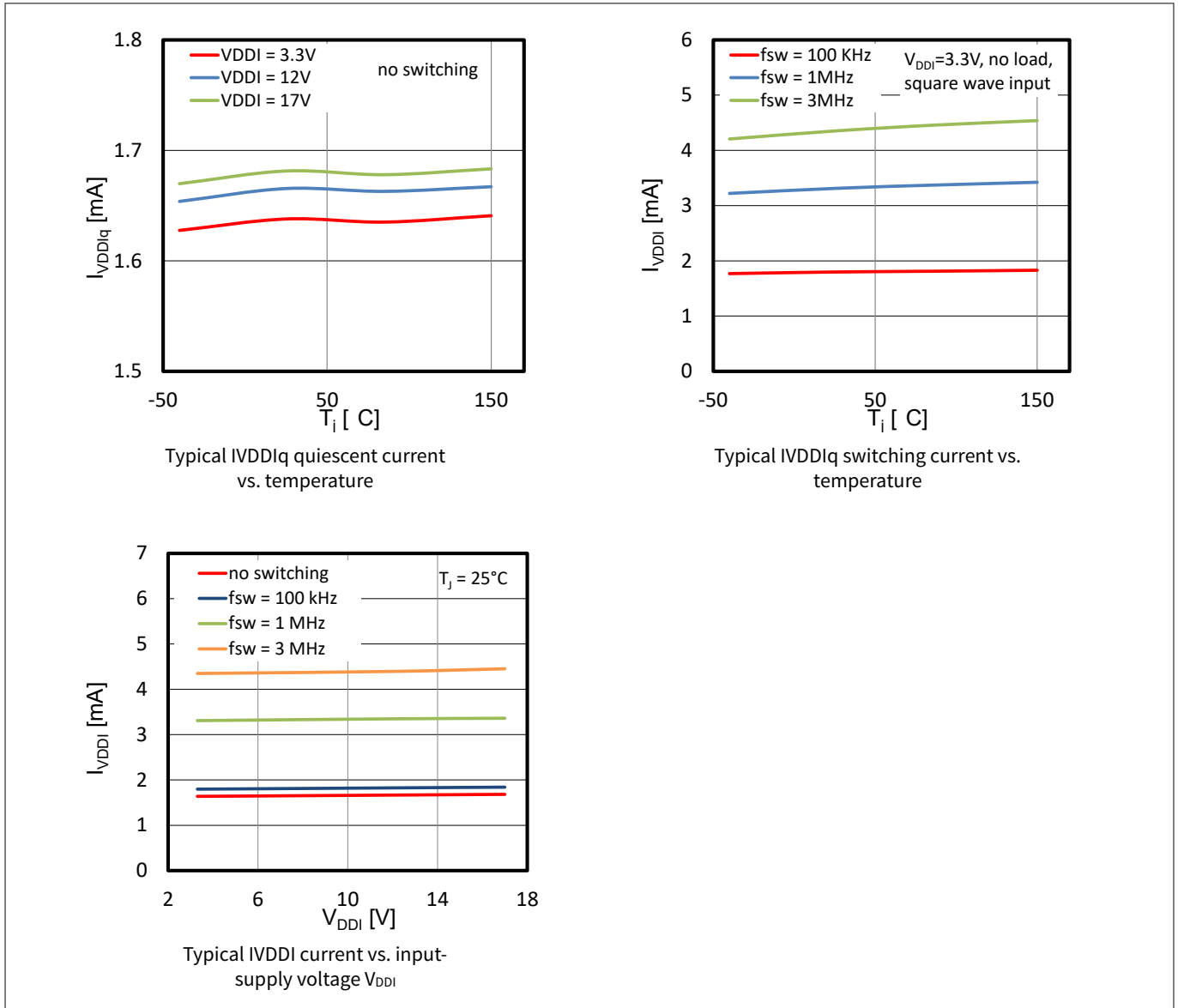

Figure 15 Input-side supply current

5 Typical characteristics

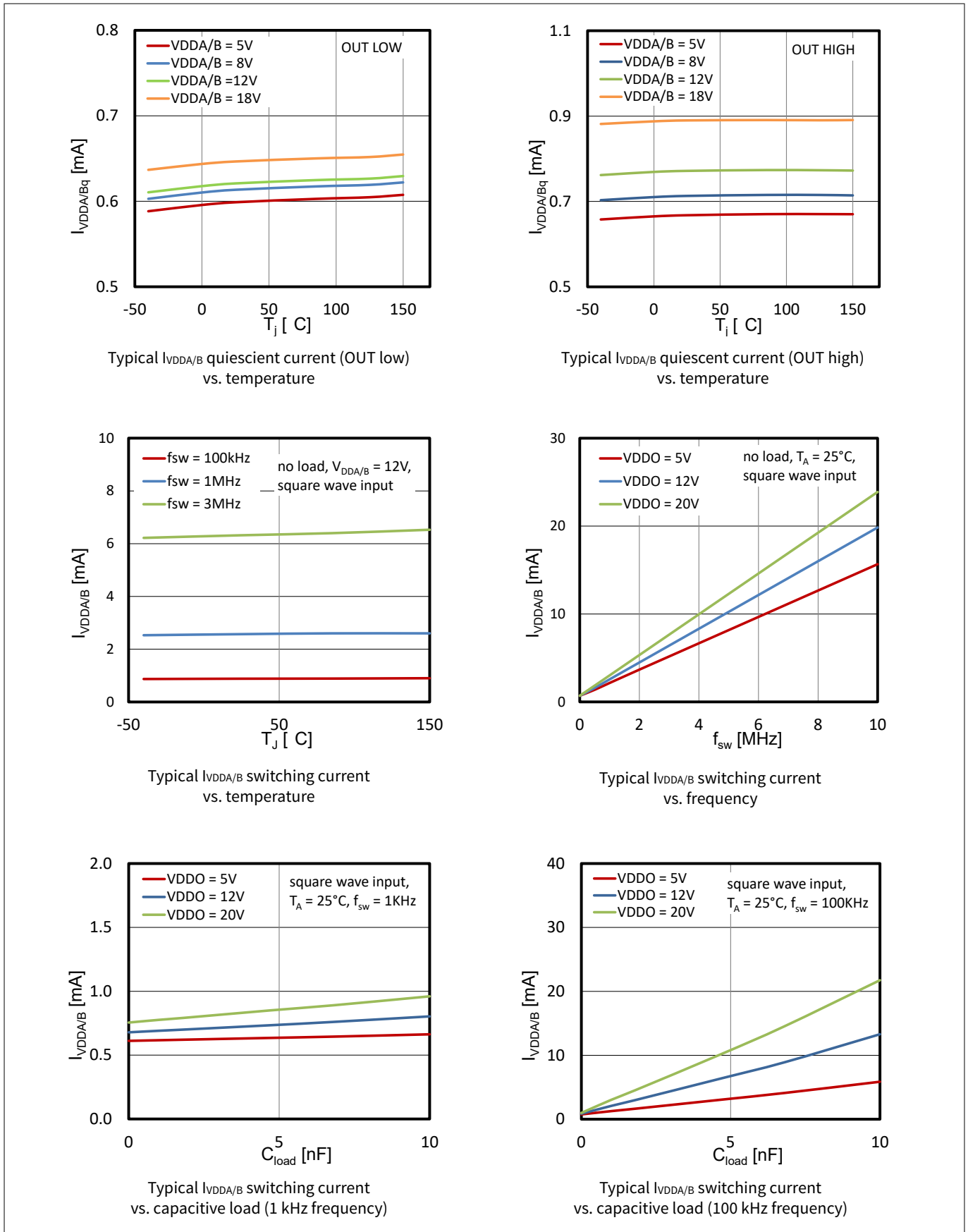

Figure 16 Output-side supply current

5 Typical characteristics

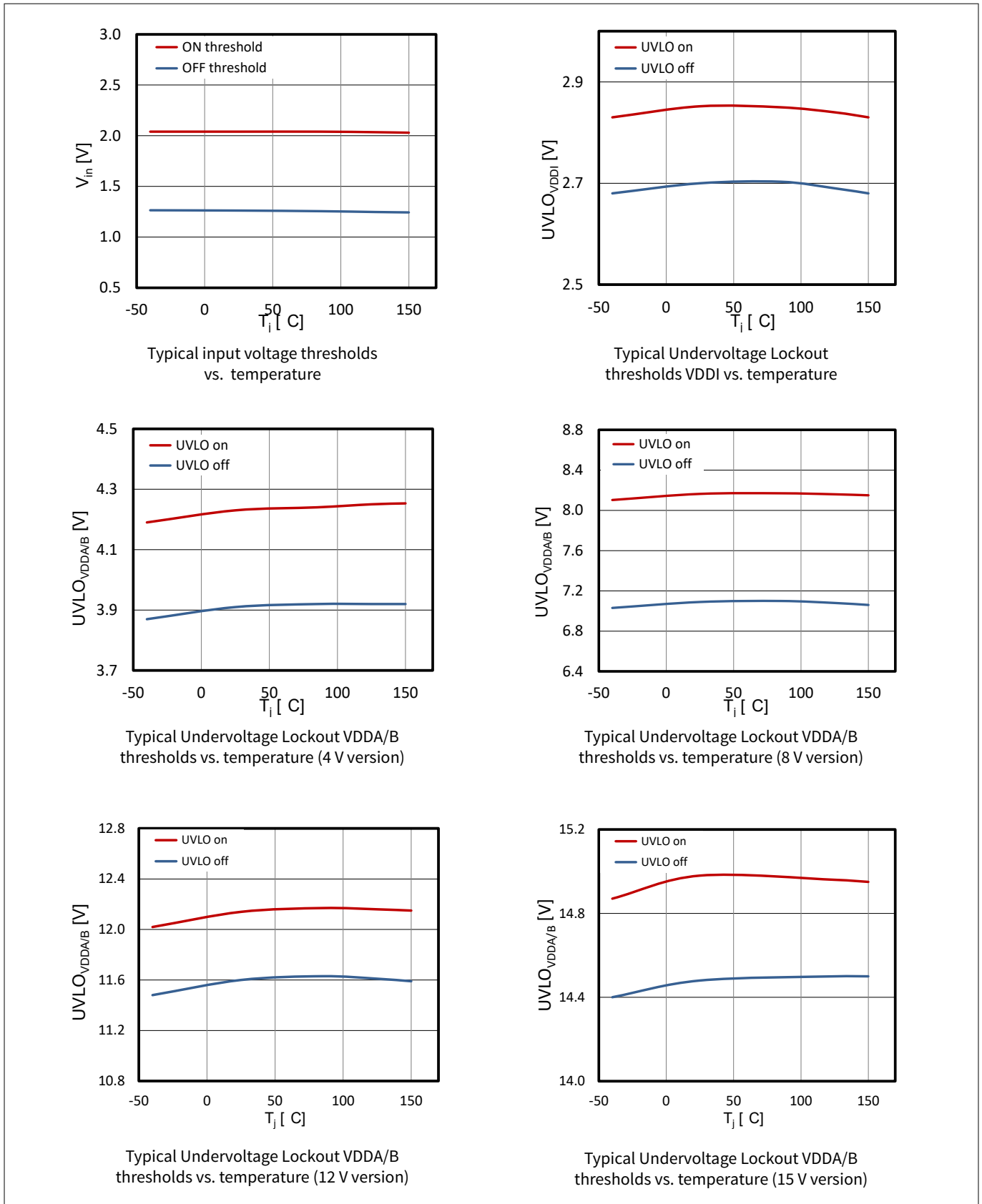

Figure 17 Input voltage thresholds and Undervoltage Lockout

5 Typical characteristics

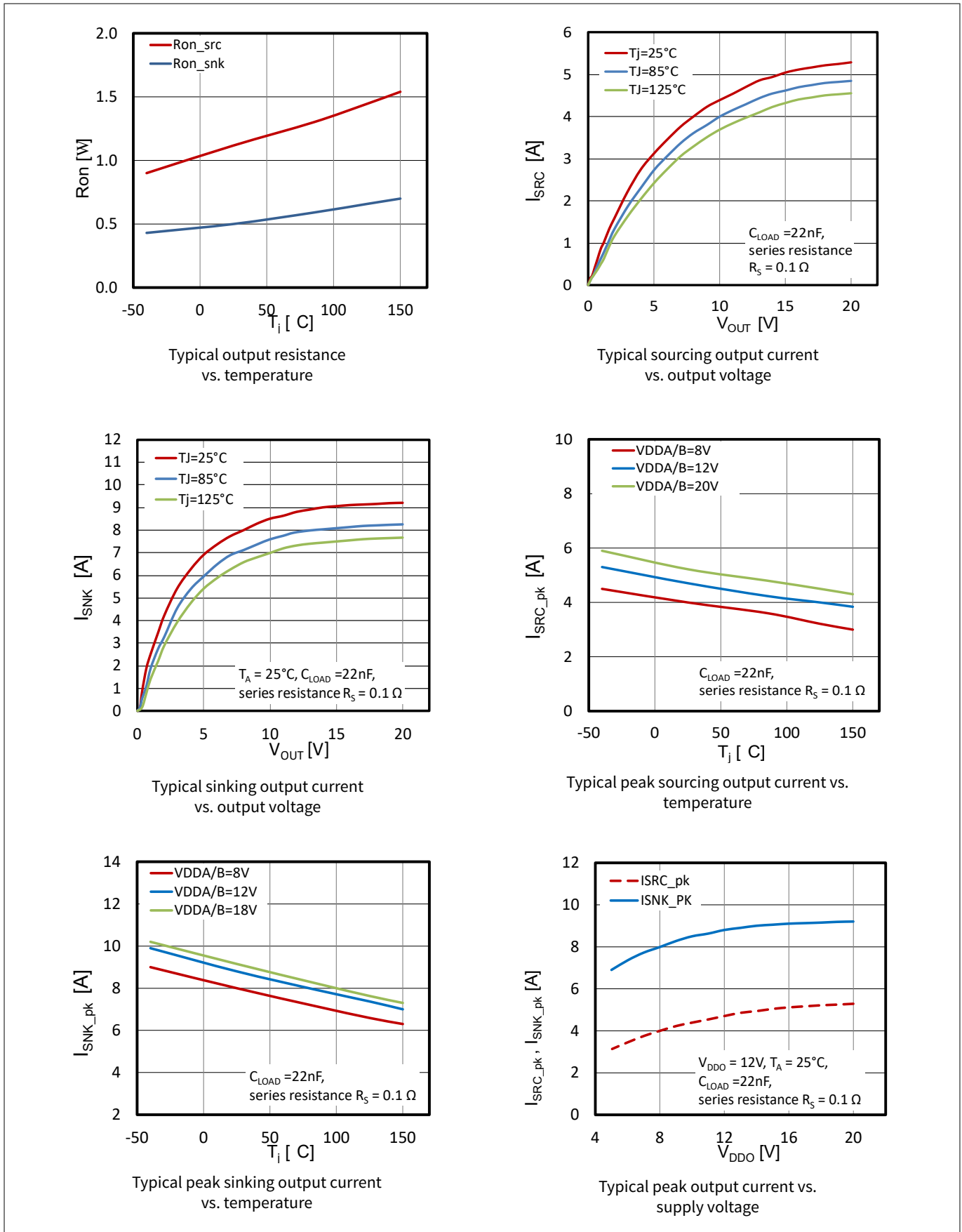

Figure 18 Typical output static characteristics

5 Typical characteristics

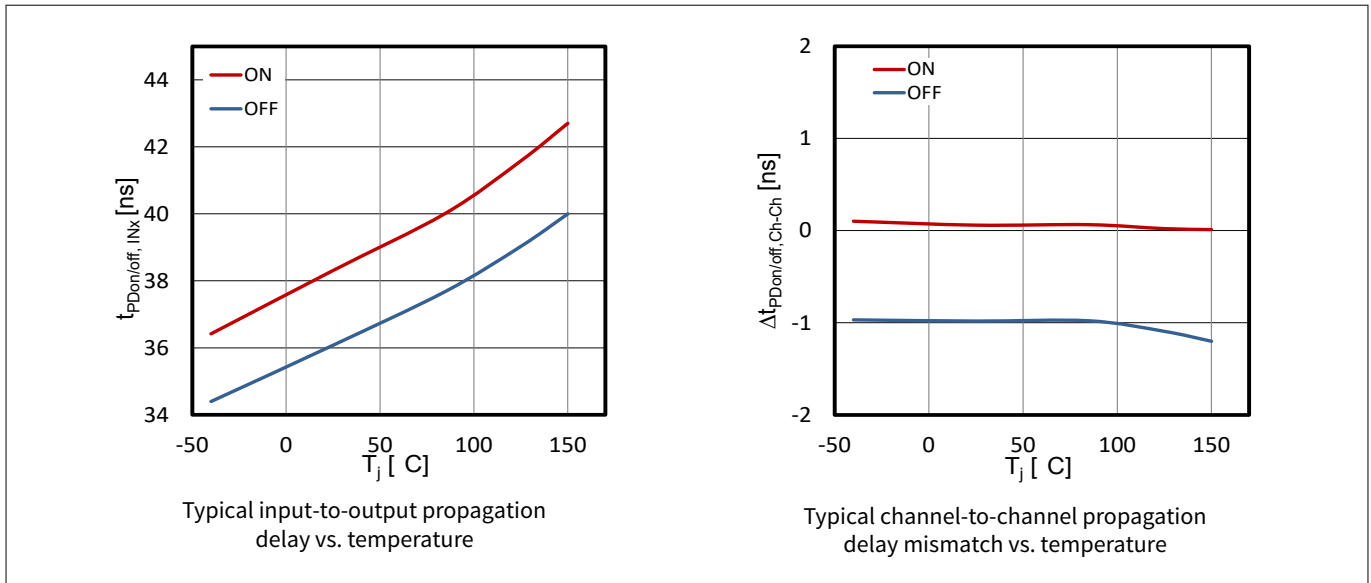

Figure 19 **Typical propagation delays**

5 Typical characteristics

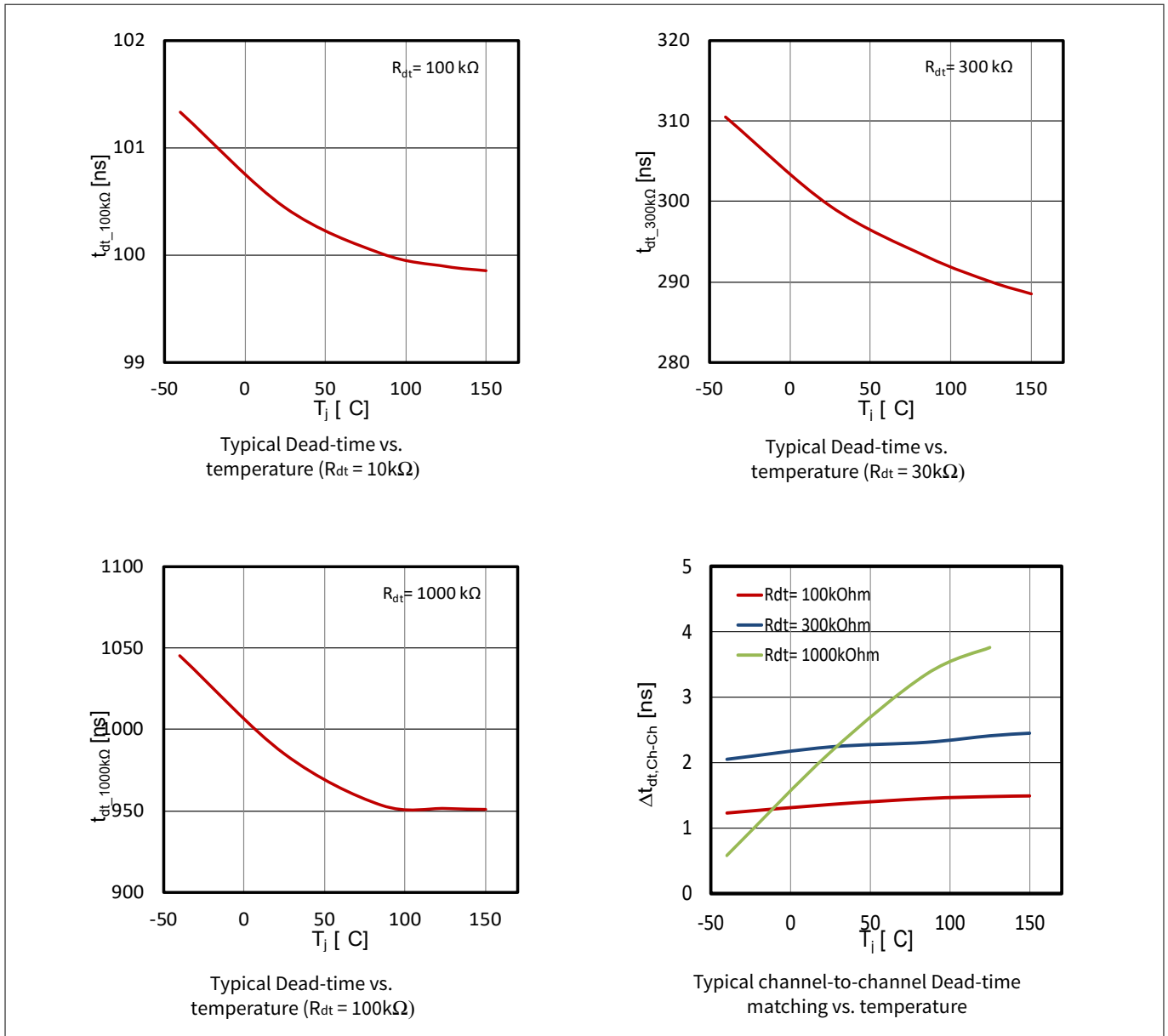

Figure 20 Typical dead-time

6 Package outline dimensions

6 Package outline dimensions

6.1 Device numbers and markings

Table 25 Device numbers and markings

Part number	Orderable part number (OPN)	Device marking
2EDR8259H	2EDR8259HXUMA1	2R8259A
2EDR7259X	2EDR7259XXUMA1	2R7259A
2EDR8259X	2EDR8259XXUMA1	2R8259A
2EDR9259X	2EDR9259XXUMA1	2R9259A
2EDR6258X	2EDR6258XXUMA1	2R6258A
2EDR8258X	2EDR8258XXUMA1	2R8258A
2EDR9258X	2EDR9258XXUMA1	2R9258A

6.2 Package DSO16-300mil

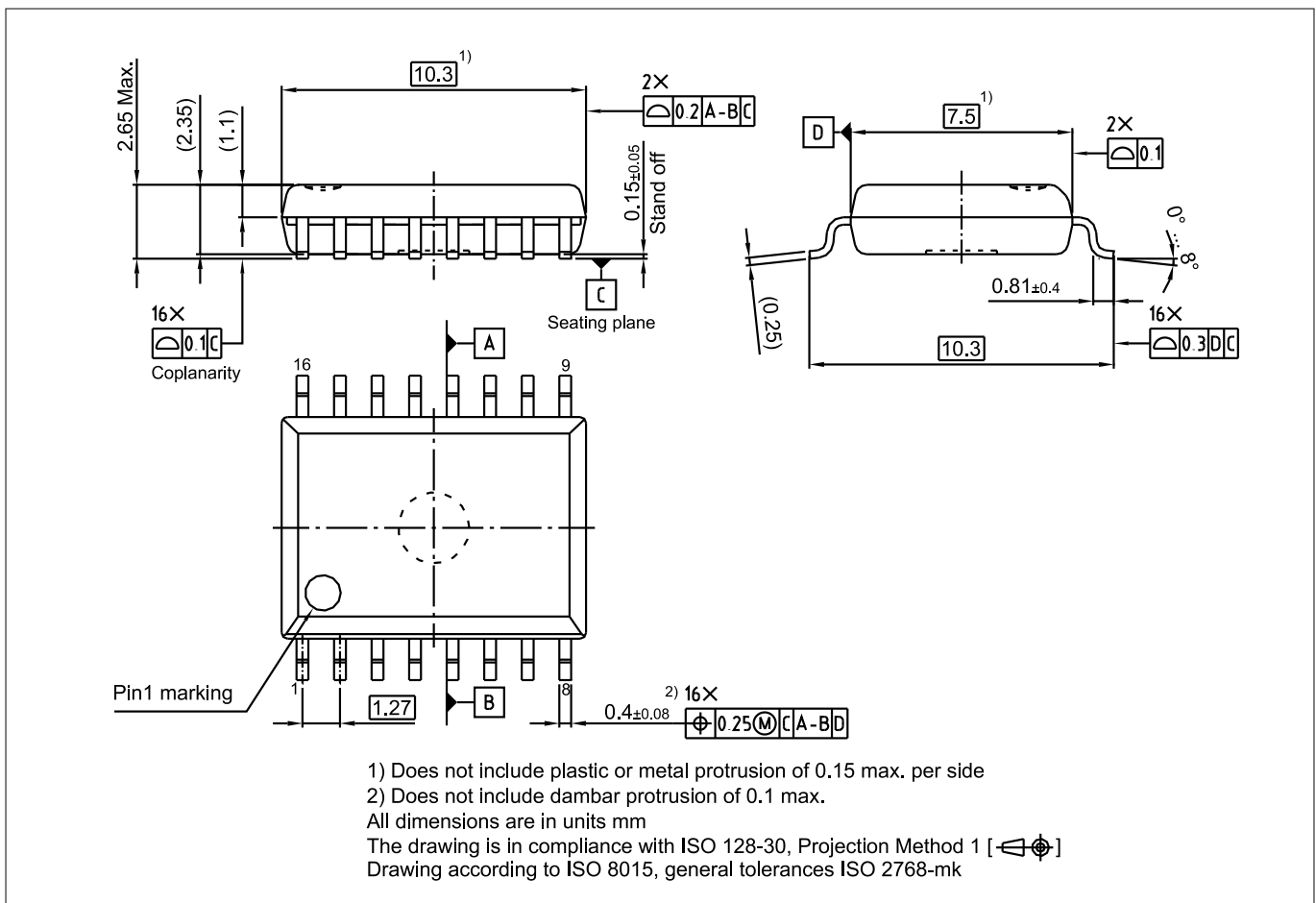

Figure 21 DSO16-300mil outline

6 Package outline dimensions

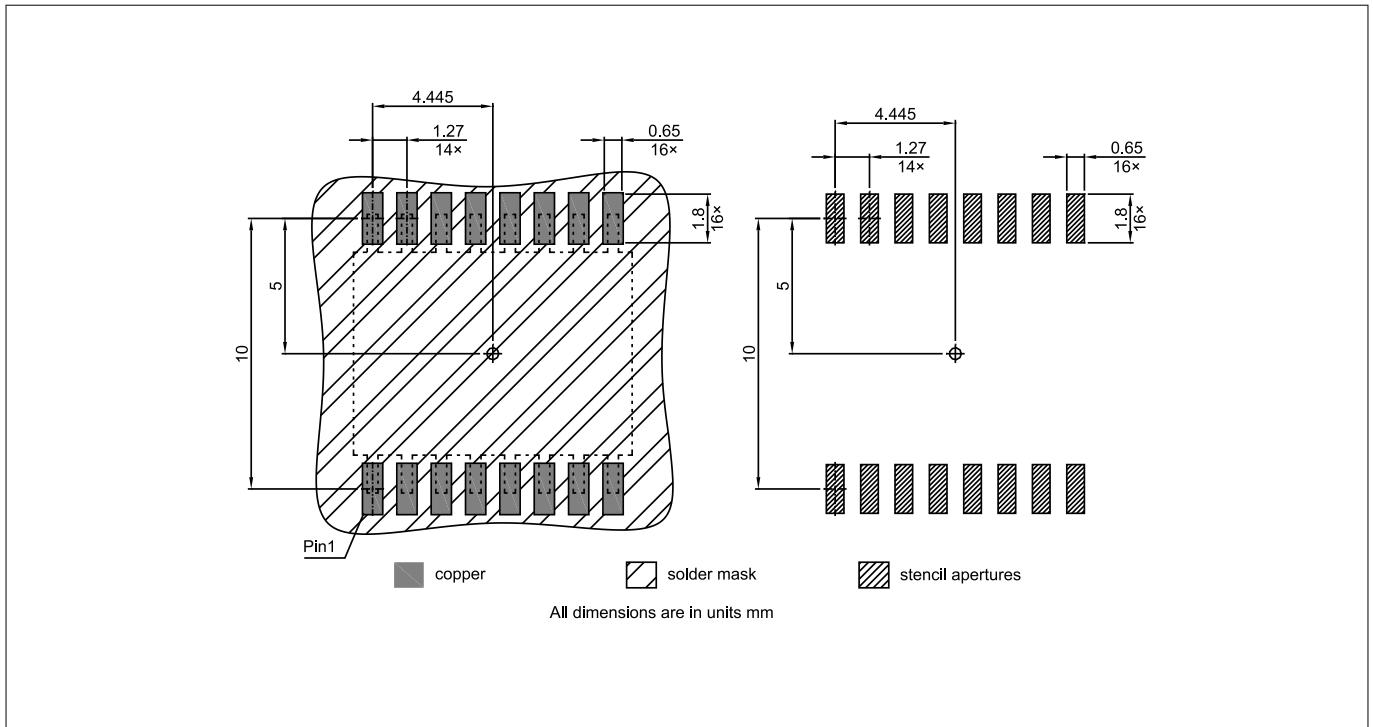

Figure 22 DSO16-300mil footprint

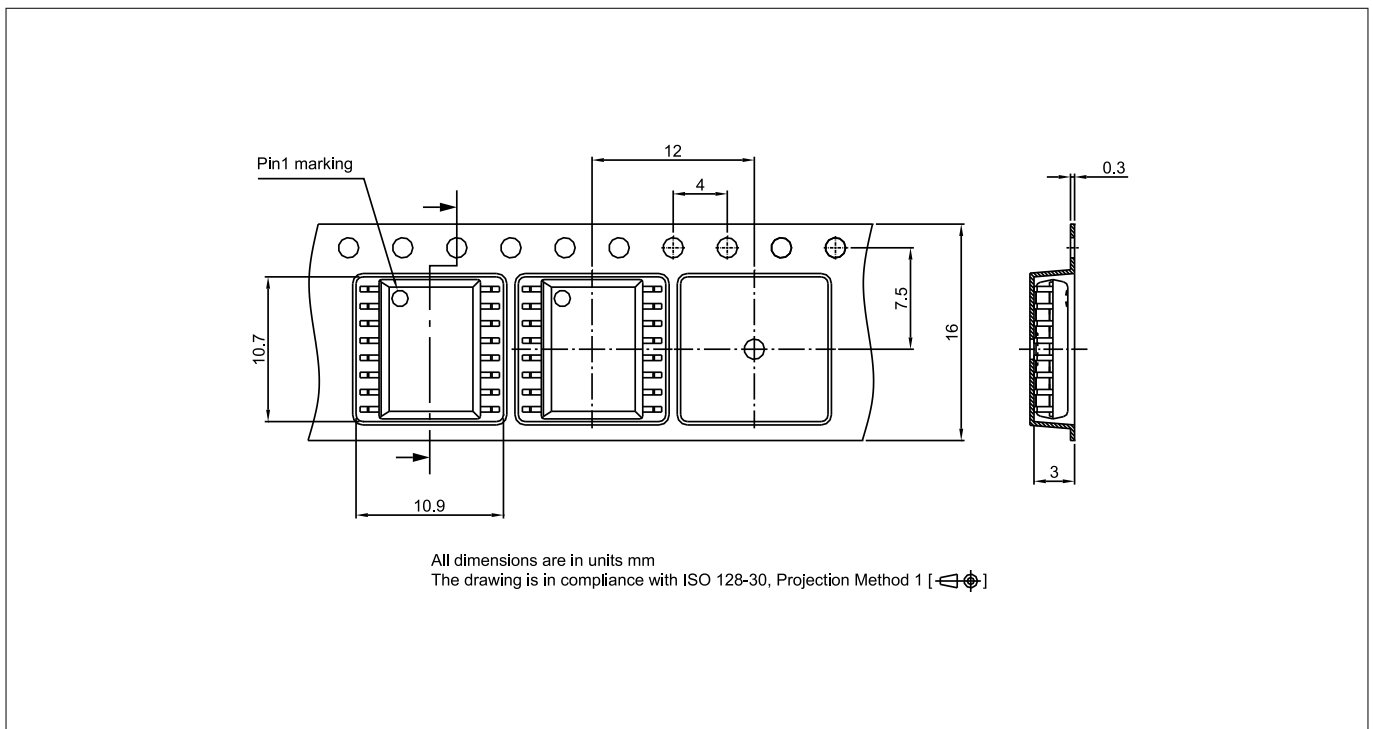

Figure 23 DSO16-300mil packing

Green Product (RoHS compliant)

To meet the worldwide customer requirements for environmentally friendly products and to be compliant with government regulations the device is available as a green product. Green products are RoHS-Compliant (i.e. Pb-free finish on leads and suitable for Pb-free soldering according to IPC/JEDEC J-STD-020). Further information on packages: <https://www.infineon.com/packages>

6 Package outline dimensions

6.3 Package DSO14-300mil

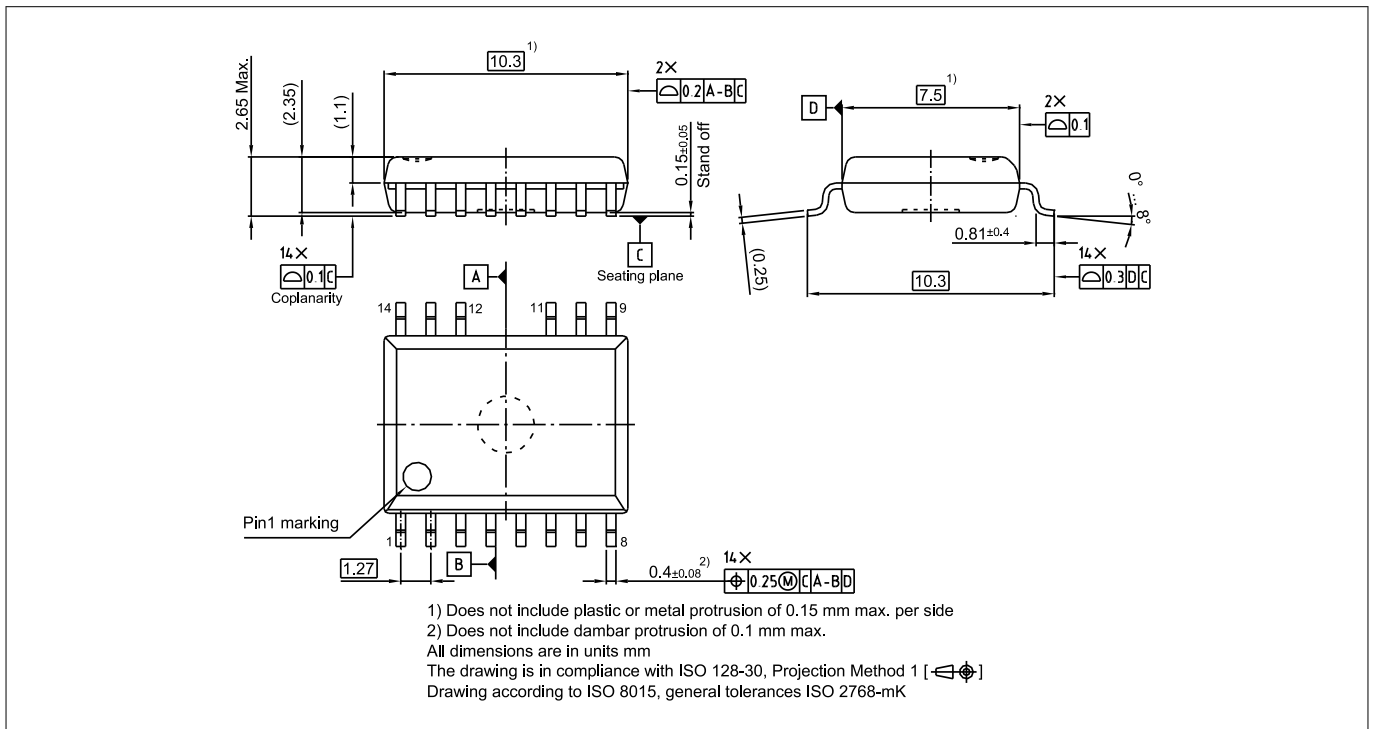

Figure 24 DSO14-300mil outline

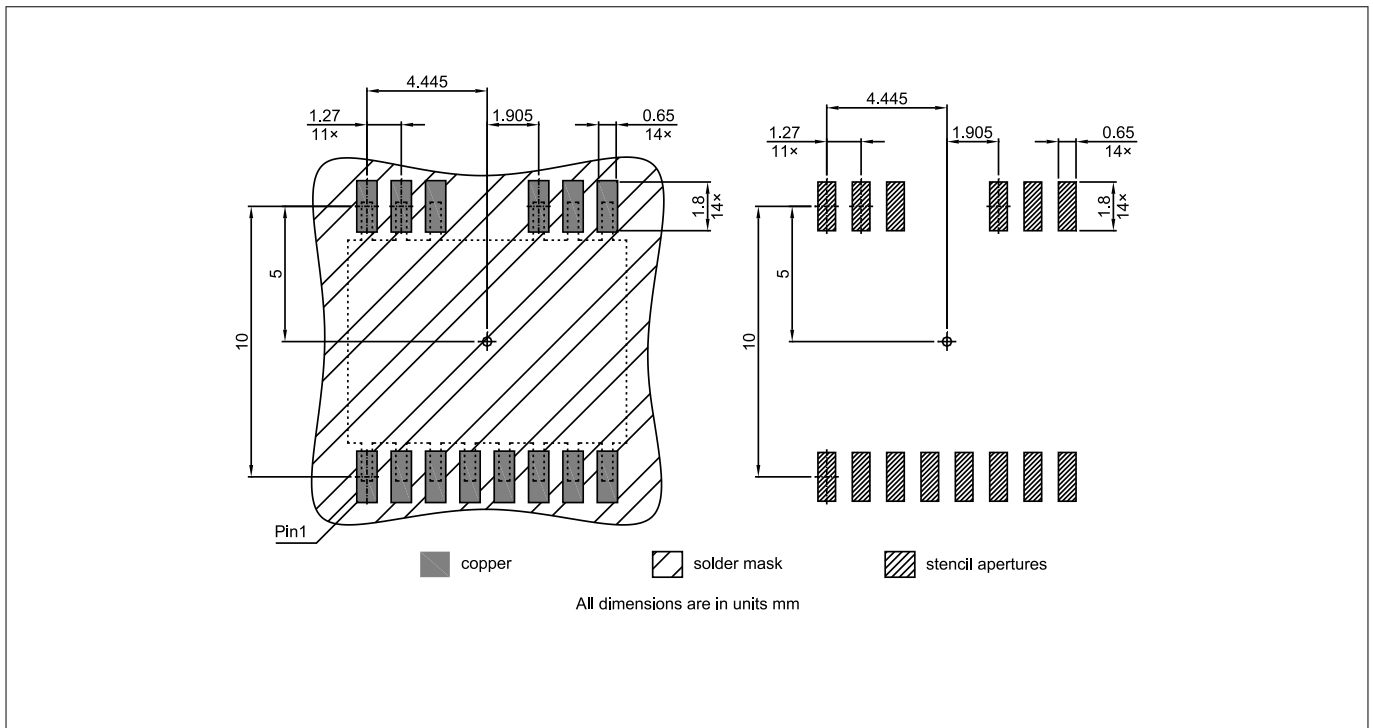

Figure 25 DSO14-300mil footprint

6 Package outline dimensions

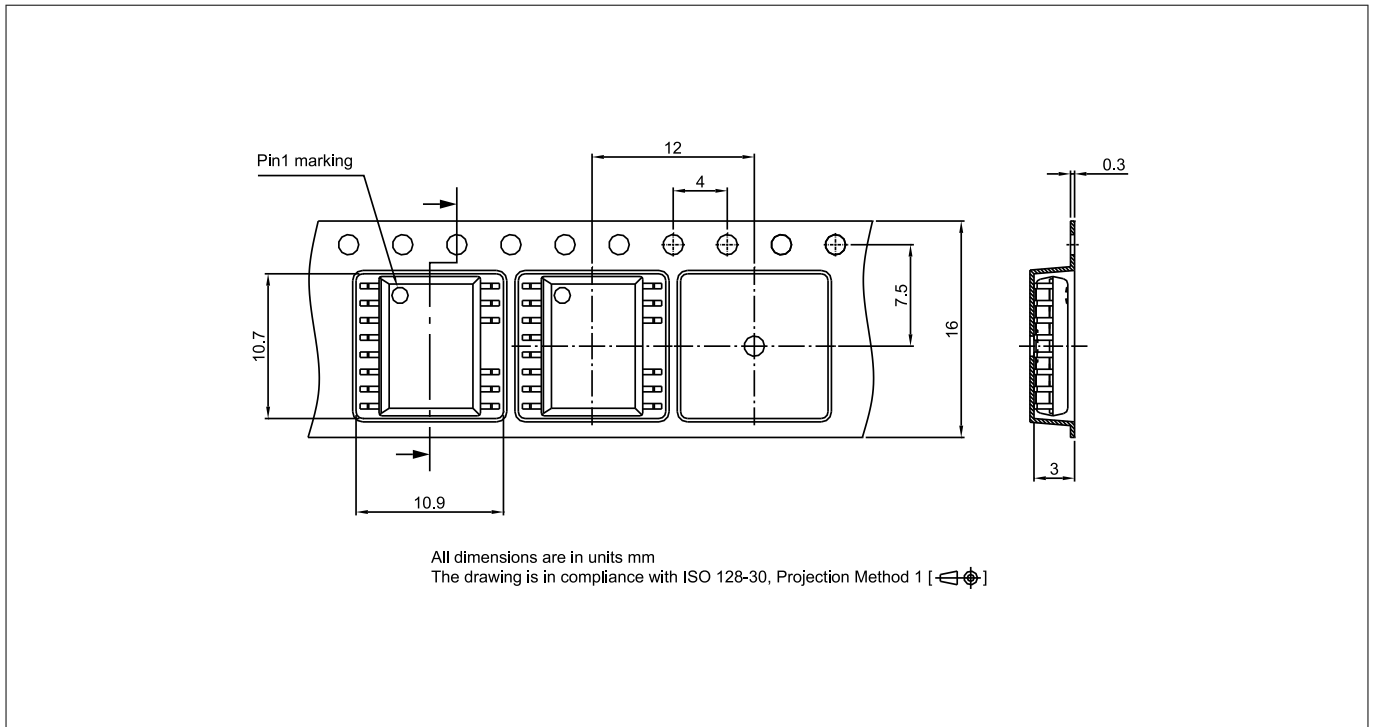

Figure 26 DSO14-300mil packing

Green Product (RoHS compliant)

To meet the worldwide customer requirements for environmentally friendly products and to be compliant with government regulations the device is available as a green product. Green products are RoHS-Compliant (i.e. Pb-free finish on leads and suitable for Pb-free soldering according to IPC/JEDEC J-STD-020). Further information on packages: <https://www.infineon.com/packages>

7 Revision history

7 Revision history

Revision	Date	Description of changes
Rev 1.4	2023-10-30	Fixed typo in Table 11 : minimum T_A : 40°C → -40°C
Rev 1.3	2023-02-27	Added condition "DTC pin connected to ground" Fixed typo in the OPN of Table 25
Rev 1.2	2023-01-19	Fixed typo in channel-to-channel propagation delay mismatch
Rev 1.1	2022-12-12	Removed watermark "restricted" "Dead-time distortion" renamed as "Channel turn-off to channel turn-on propagation delay mismatch" in Table 21
Rev 1.0	2022-12-09	Initial release

Trademarks

All referenced product or service names and trademarks are the property of their respective owners.

Edition 2023-10-30

Published by

Infineon Technologies AG

81726 Munich, Germany

© 2023 Infineon Technologies AG

All Rights Reserved.

Do you have a question about any aspect of this document?

Email: erratum@infineon.com

Document reference

IFX-jqf1648202404767

Important notice

The information given in this document shall in no event be regarded as a guarantee of conditions or characteristics ("Beschaffheitsgarantie").

With respect to any examples, hints or any typical values stated herein and/or any information regarding the application of the product, Infineon Technologies hereby disclaims any and all warranties and liabilities of any kind, including without limitation warranties of non-infringement of intellectual property rights of any third party.

In addition, any information given in this document is subject to customer's compliance with its obligations stated in this document and any applicable legal requirements, norms and standards concerning customer's products and any use of the product of Infineon Technologies in customer's applications.

The data contained in this document is exclusively intended for technically trained staff. It is the responsibility of customer's technical departments to evaluate the suitability of the product for the intended application and the completeness of the product information given in this document with respect to such application.

Warnings

Due to technical requirements products may contain dangerous substances. For information on the types in question please contact your nearest Infineon Technologies office.

Except as otherwise explicitly approved by Infineon Technologies in a written document signed by authorized representatives of Infineon Technologies, Infineon Technologies' products may not be used in any applications where a failure of the product or any consequences of the use thereof can reasonably be expected to result in personal injury.